

We pioneer motion

Cement Playbook

Schaeffler products and services in the cement industry

Interactive
e-booklet



Cement Playbook

The Cement Playbook supports Schaeffler's sales activities in the cement industry. It provides valuable information about all aspects of the industry and shows what makes Schaeffler the leading technology partner for the sector: the products, systems, and solutions with which Schaeffler helps the industry to reach its goals. From the production process and the (user-specific) product and service portfolio to customized solutions, this Playbook answers every question, all for the purpose of meeting our goal of giving our customers the best advice possible.

















Cement Production Process

Cement

- is a hydraulic binder used to make the building materials mortar and concrete.
- is an inorganic and non-metallic building material.
- consists of natural raw materials such as limestone, clay, sand, and iron ore.

1

Raw material extraction
Crushing and transportation

2

Raw material preparation I
Storage and homogenization

3

Raw material preparation II
Drying and raw grinding

4

Clinker burning
Rotary kiln

5

Cement grinding
Grinding the clinker

6

Delivery and shipping
Silo trucks/
hand trucks

7

Quality control and environmental protection
Central control station and filter system



Cement Production Process

1 Raw material extraction Crushing and transportation

Limestone, clay, and marl are extracted in quarries by blasting. Wheel loaders and dump trucks transport the raw materials to the crushing plants. There, the rock is crushed to roughly the size of road gravel.

2 Raw material preparation I Storage and homogenization

The raw gravel is transported by conveyor belts, ropeways, or track systems to the gravel hall, where it is stored in the blending bed and homogenized.

3 Raw material preparation II Drying and raw grinding

The raw mix of crushed stone and aggregates, such as silica sand and iron ore, is produced using batching equipment. Vertical roller mills and ball mills grind the mixture to fine sizes and dry it at the same time before it is conveyed to the raw meal silos for homogenization.



Cement Production Process

4 Clinker burning Rotary kiln

The raw meal is fired in rotary kilns with cyclone preheaters. After the CO_2 has been largely expelled from the raw meal in the cyclone preheater and calciner, it is heated up to approx. $1,450^\circ\text{C}$ in the rotary kiln. Chemical transformation (called sintering) produces the cement clinker.

5 Cement grinding Grinding the clinker

After burning, the clinker is cooled down and stockpiled in clinker silos to accommodate changing demand. From there, the clinker is fed into ball mills or high-pressure grinding mills, where, depending on the type of cement, it is also ground with other main constituents, such as limestone and granulated blast furnace slag, to produce very fine cement. To ensure that the cement does not later solidify immediately after mixing with water, gypsum and anhydrite are added during grinding as solidification regulators.



Rotary kiln:
burning at up to

1,450 °C



Cement Production Process

6 Delivery and shipping Silo trucks/hand trucks

The finished cement is temporarily stored in silos, separated by type. From there, it is usually shipped out in bulk to freight terminals and then onto road, rail, or sea. Only a small percentage of the cement is filled by packaging machines, stacked by automatic palletizers, and sold to customers as bagged goods.

7 Quality control and environmental protection Central control station and filter system

The entire production process is constantly monitored from the central control station, where all the data from the plants and the laboratory is compiled. Highly qualified production controllers operate and secure the plant with the support of microprocessor technology.



Cement Production Process

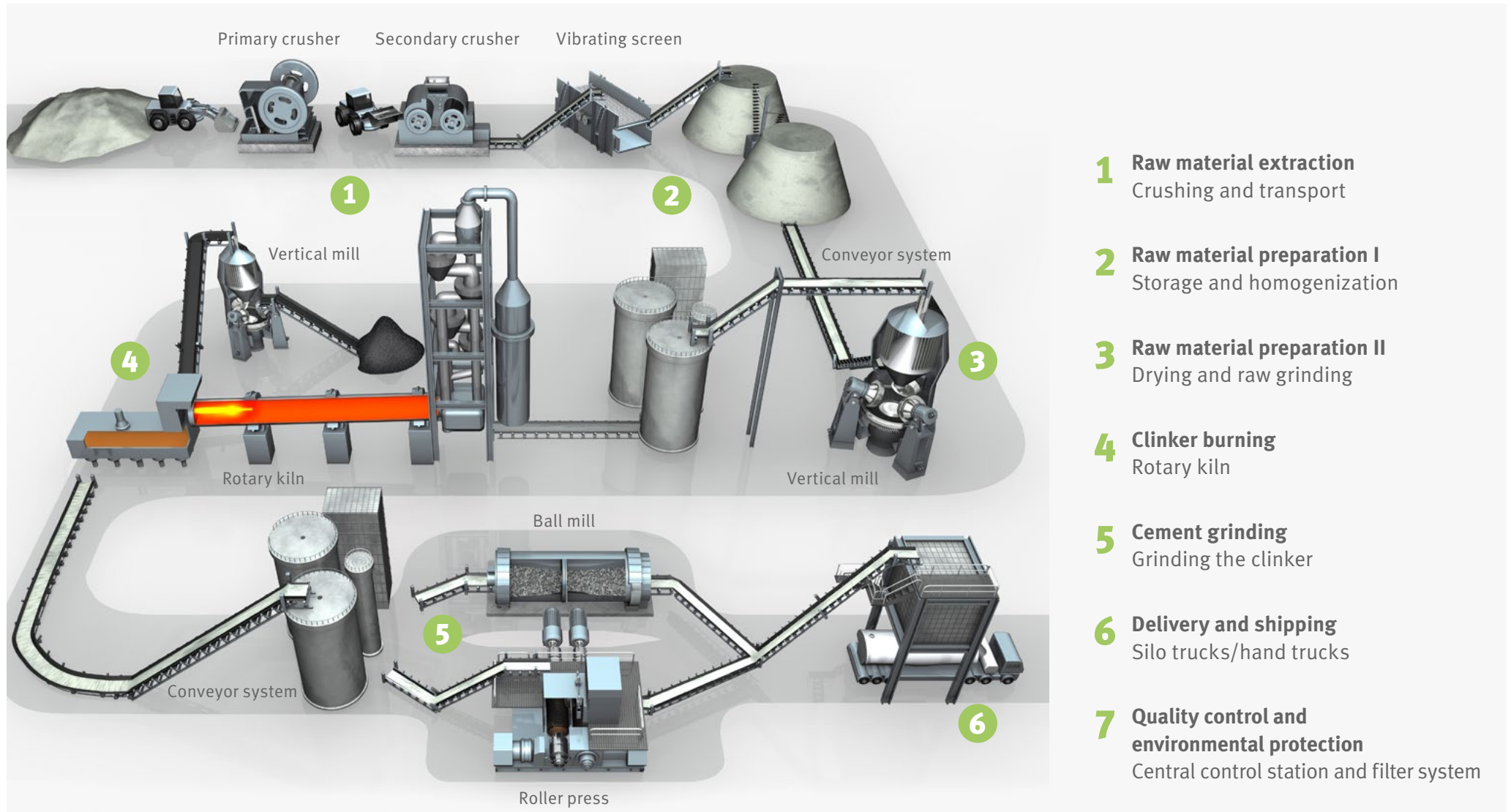

- 1 Raw material extraction**
Crushing and transport
- 2 Raw material preparation I**
Storage and homogenization
- 3 Raw material preparation II**
Drying and raw grinding
- 4 Clinker burning**
Rotary kiln
- 5 Cement grinding**
Grinding the clinker
- 6 Delivery and shipping**
Silo trucks/hand trucks
- 7 Quality control and environmental protection**
Central control station and filter system

Overview of the Most Important Applications

Crusher



Vibrating screens



Rotary kilns



Roller presses



Vertical mills



Ball mills



Figures, Data, and Facts

0.4 PRODUCTION
OUTPUT
of one plant per year
TO **5 mn.t**

~ **10%**
electric

~ **90%** ENERGY
REQUIREMENTS
thermal

Large proportion of maintenance outsourced

(Expert services and plant overhaul)

83%

of the mass of a 2.3 MW
wind turbine consists of cement

€0.26 Potential loss per day
TO **€1.3 mn.** (in case of complete plant shutdown)



Did you know?

Energy, or rather fuel, is an important cost factor. Many plants have successfully switched to alternative fuels (such as waste-to-energy) to improve their environmental footprint and cost structure.

The Biggest Cement Producers

The biggest countries of production by region

Africa	Capacity (mn. tons/year)
Egypt	79.2
Nigeria	49.3
Algeria	36.8
Morocco	28.1
South Africa	18.6

Americas	Capacity (mn. tons/year)
United States	126.4
Brazil	99.9
Mexico	60.2
Colombia	22.8
Argentina	21.2

Asia	Capacity (mn. tons/year)
China	2,500.0
India	450.1
Vietnam	149.2
Indonesia	102.6
Iran	79.5

Europe	Capacity (mn. tons/year)
Russia	116.0
Turkey	107.4
Spain	52.4
Italy	45.5
Germany	37.3

Middle East	Capacity (mn. tons/year)
Saudi Arabia	72.7
United Arab Emirates	39.7
Iraq	29.1
Qatar	14.5
Yemen	10.6

Top ten countries of production

Country	Number of plants	Capacity (mn. tons/year)
China	875	2,500.0
India	254	450.1
Vietnam	91	149.2
United States	105	126.4
Russia	71	116.0
Turkey	69	107.4
Indonesia	34	102.6
Brazil	93	99.9
Iran	71	79.5
Saudi Arabia	21	72.7
Other	1,257	1,594.8
Total	2,941	5,406.5



The biggest producers globally

Producer	Capacity (mn. tons/year)
CNBM	530
Anhui Conch	368
Holcim	313
HeidelbergCement	186
UltraTech Cement	95.3
Cemex	91.4
China Resources	85.3
Votorantim	65.7
CRH	61.0
Semen Indonesia	51.5

Source: Global-Cement-Directory-2022.pdf

Schaeffler for the Cement Industry

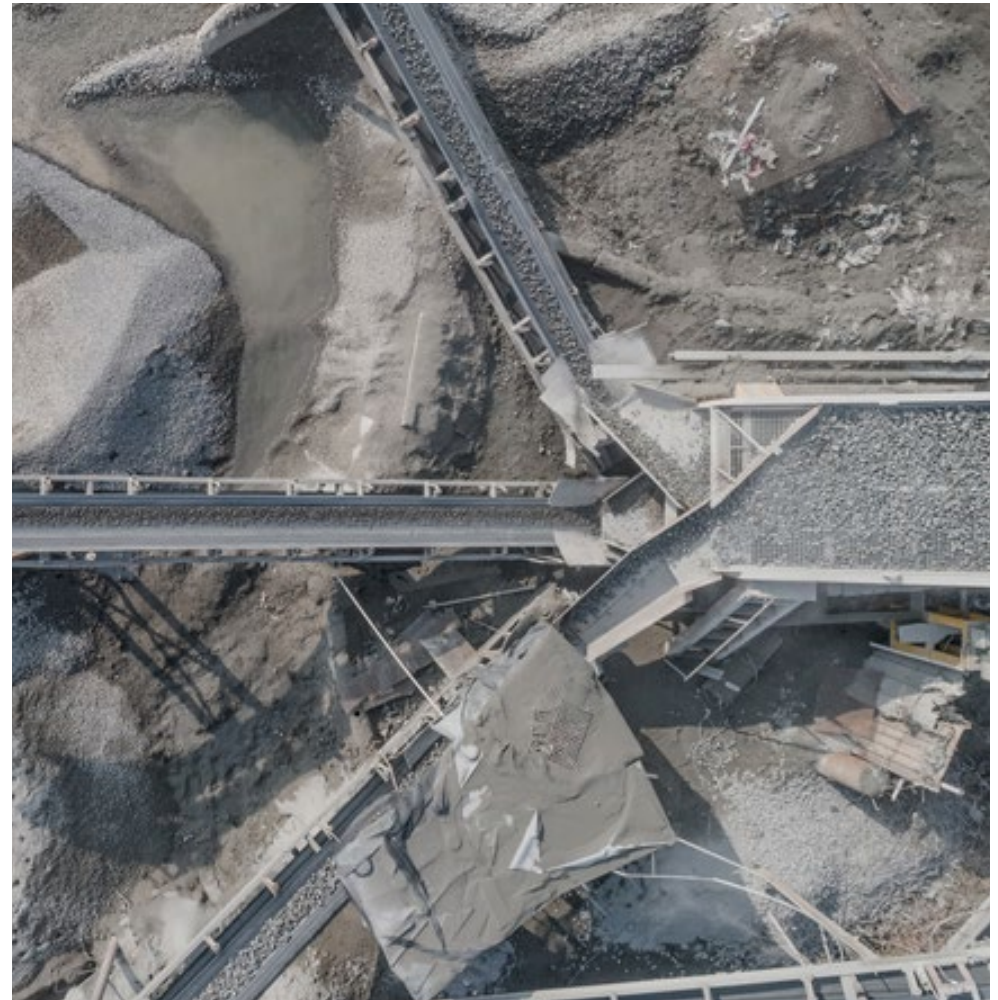

Schaeffler – Your Partner for the Cement Industry

Schaeffler is a partner of all the leading manufacturers and operators in the raw materials processing industry. Our broad range of products and services enables us to help our customers worldwide optimize their plant processes.



Successful together

The harsh operating conditions in the cement industry impose tough demands on the performance and operational safety of all the components used. Thanks to years of close collaboration with our customers and extensive shared experience, we have a thorough understanding of the special challenges the raw materials processing industry presents. That means we are able to offer solutions that always utilize state of the art technologies while keeping the needs of the industry in mind.

With Schaeffler, companies can also rely on:

- A global network of experts
- Broad-based expertise with bearings
- User-friendly engineering tools in medias
- Sustainable product concepts

Benefits offered by Schaeffler in the cement industry at a glance

Top supplier to plant manufacturers

End-to-end expert knowledge

Leader in wireless machine diagnostics

Forward-looking with automated lubrication

Proven in practice: our customer success stories

We regularly work with our customers to put special projects into practice with individual solutions which combine or complement products and services from our catalog.

Original equipment manufacturers (OEM)

Maintenance, repair, and operations (MRO)

Schaeffler Products and Services for the Cement Industry



Avoiding unnecessary plant downtime is what drives us in the development and manufacturing of innovative and high-quality rolling bearing solutions. Through intensive dialog with research and development partners as well as with manufacturers, operators, and business partners, we ensure that our bearings are perfectly designed for the adverse operating and ambient conditions in industries that process raw materials. We also ensure that they provide latitude for a wide range of individual solutions. Schaeffler further offers a wide range of products and services that are the perfect complement to its range of bearings and keep machines running.

Schaeffler's rolling bearings for the cement industry



Your advantages

- Decades of experience
- Proven quality
- High level of operational safety
- Long life
- High load-carrying capacity and stability
- Reduced maintenance requirements
- Easy to install and remove
- Temperature resistance
- Suitable for heavy vibration stress

Schaeffler's services for the cement industry



Added Value in Every Phase of the Life Cycle

Our customers are at the center of everything we do. No matter what industry they come from: we equip them with our innovations for pioneering motion. From bearing solutions to complete linear guidance systems, that's how we pioneer motion for the industry of the future.

What's more, we create innovations to extend the lifetime of these solutions. And with over 100 years of experience in the bearing business, we have earned the experience it takes to add value to every stage of the solution lifetime.

From the moment one of our solutions is installed to how it is operated and maintained: Schaeffler has a full portfolio of solutions and services to support maintenance teams and managers. Called Schaeffler Lifetime Solutions, the portfolio includes mounting tools and services as well as solutions and services for condition monitoring and lubrication.

But the lifetime does not end there. Schaeffler also offers remanufacturing services to extend the lifecycle of bearings belonging to our customers and expert services to optimize their use. And that's how we add value over the lifetime for our customers.



Bearing Solutions for the Cement Industry

As one of the world's largest rolling bearing manufacturers, Schaeffler is a key partner for all leading system manufacturers and operators in the cement industry. Based on our in-depth industry knowledge, we provide our customers with optimum bearing solutions for their applications – for maximum reliability even under the harshest ambient conditions.

Navigation instructions:
With the help of this overview, you can quickly and easily access the corresponding content in the Playbook by clicking the respective application or product in the table.

	1	2	3	4	5	6	7	8	9
1	●	●	●	●	●	●	●	●	●
2	●	●		●	●		●	●	●
3	●		●		●				
4	●			●	●				
5	●		●			●	●	●	
6						●	●	●	
7				●					
8	●								
9							●	●	●



Lifetime Solutions for the Cement Industry

Schaeffler Lifetime Solutions offers an end-to-end portfolio specially tailored to the needs of maintenance teams and plant managers. From assembly to condition monitoring and smart lubrication, our products, solutions, and services are perfectly coordinated and help prevent up to 100% of all machine outages. Keep your machines rolling with Schaeffler.

Navigation instructions:
With the help of this overview, you can quickly and easily access the corresponding content in the Playbook by clicking the respective application or product in the table.

1	●	●	●	●	●	●	●	●
2	●	●	●	●	●	●	●	●
3		●		● ¹		● ¹	●	●
4		● ¹		● ¹		● ¹	●	●
5		● ¹	● ¹		● ²	● ¹	●	●
6	●	●	●	●		●	●	●
7				●				
8	●	●	●	●	●	●	● ²	●
9				●	●			
10	●	●	●	●	●	●	●	●
11	●		●	●	●	●		
12	●		●	●	●	●		
13	●	●	●	●	●	●	●	●
14	●			●	●	●		



Our comprehensive range of Bearing Solutions and Lifetime Solutions is rounded out by a spectrum of expert services and training programs.

¹ For auxiliary units

² Limitations on usage

Application-Specific Solutions



Crushers

Extreme performance under the toughest conditions

Task in the cement production process

- Crushing rock for cement production

Challenges

- Heavy radial loads
- Impact loads
- Shaft deflections
- Intensive dust generation

Schaeffler's solutions

- Spherical roller bearings with the X-life seal of quality
- SNS plummer block housings
- ARCANOL LOAD lubricants with EP additives
- Condition monitoring solutions for rotating rolling bearings to increase system availability



Vibrating Screens

Endurance test for every bearing

Task in the cement production process

- Screening and homogenization of the raw material

Challenges

- Extremely heavy radial loads, including impact loads
- Fretting corrosion between bearing and shaft
- Special stress on the bearing cages due to vibrations and radial acceleration
- Circumferential shaft deflections
- Intensive dust generation

Schaeffler's solutions

- Spherical roller bearings with the X-life seal of quality and a thin-layer chromium-plated bore according to T41D (Durotect CK)
- ARCANOL LOAD lubricants with EP additives
- Condition monitoring solutions to increase system availability



Rotary Kilns

High risk of extra costs in the event of shutdowns

Task in the cement production process

- Firing of the raw meal with cyclone preheater
- Expulsion of CO₂ from the raw meal in the cyclone preheater and calciner
- Chemical conversion of the raw meal (called sintering) into cement clinker

Challenges

- Increased temperatures
- Impact loads
- High radial and axial forces
- Intensive dust generation

Schaeffler's solutions

- Reliable radial and axial track rollers as complete ready-to-mount units
 - Spherical roller bearings with the X-life seal of quality
 - Lubrication with ARCANOL high-performance greases



Roller Presses

High level of efficiency with little energy

Task in the cement production process

- Grinding clinker into cement
- Grinding of crushed raw stone and burned clinker
- Increasingly replacing ball mills (more compact design, better efficiency)

Challenges

- Heavy radial loads
- Shaft deflections
- Intensive dust generation
- Difficult relubrication conditions

Schaeffler's solutions

- Multi-row cylindrical roller bearings and spherical plain bearings with the X-life seal of quality for high-level load-carrying capacity in compact installation spaces
- Spherical roller bearings with specially profiled rollers
- ARCANOL LOAD lubricants with EP additives
- Condition monitoring solutions on the main bearings, large gear units, and auxiliary units to increase system availability



Vertical Mills

High level of bearing stress due to large and dynamic loads

Task in the cement production process

- Grinding and drying of raw materials for clinker production
- Finish grinding of cement
- Grinding coal for rotary kiln firing

Challenges

- Heavy radial and axial loads
- Heavy impact loads
- Intensive dust generation
- Difficult lubrication conditions (mixed friction)
- High temperatures

Schaeffler's solutions

- Tapered roller bearings, cylindrical roller bearings, spherical roller bearings, and spherical plain bearings with the X-life seal of quality for high load-carrying capacities in compact installation spaces
- Performance enhancement through material and coating solutions
- Excellent wear resistance of Schaeffler products
- Condition monitoring solutions on large gear units and auxiliary units to increase system availability



Ball Mills

High operational reliability through extreme temperature fluctuations

Task in the cement production process

- Fine grinding of clinker to cement

Challenges

- Compensation of misalignments
- Impact loads
- Extreme temperature fluctuation
- Difficult lubrication conditions (mixed friction)
- Intensive dust generation

Schaeffler's solutions

- Spherical roller bearings with the X-life seal of quality
- SNS plummer block housings for the drive system
- Special Schaeffler housing solutions for the main bearing
- Condition monitoring solutions for the main rolling bearings, gear units, and auxiliary units to increase system availability



Conveyor Systems

The connecting link between all processes

Task in the cement production process

- Conveyor belt systems for transporting rock and cement clinker

Challenges

- Heavy loads
- Dust and dirt accumulation
- Important aggregate for the supply of raw materials to the cement plant
- Extensive maintenance potentially required (many hard-to-reach bearing locations)

Schaeffler's solutions

- Sealed spherical roller bearings with the X-life seal of quality
- Split spherical roller bearings for faster bearing replacements and shorter downtime
- SNS and SES housings including variable sealing options
- OPTIME, an intelligent and wireless condition monitoring solution for increasing the availability of conveyor belt gear units and auxiliary units
- Automated lubrication with our CONCEPT lubricators, such as the intelligent OPTIME C1



Fans, blowers

Reliable air supply ensures trouble-free plant operation

Task in the cement production process

- For cooling, drying, and air/gas routing during the burning process
- Air-assisted transportation of ground material

Challenges

- Heavy axial loads
- High speeds
- Imbalance
- Misalignment
- Dust and dirt accumulation

Schaeffler's solutions

- Spherical roller bearings with the X-life seal of quality
- SNS and SES housings including variable sealing options
- OPTIME, an intelligent and wireless condition monitoring solution for increasing plant availability of auxiliary units
- Automated lubrication with our CONCEPT lubricators, such as the intelligent OPTIME C1
- ARCANOL high-performance greases



Electric Motors

Drive the industry

Task in the cement production process

- Responsible for the drives of many cement industry applications

Challenges

- Long-term machine availability with lowest-possible maintenance overheads
- Risk of current discharge in bearing
- Lifetime lubrication
- High operating temperatures
- High operating speeds

Schaeffler's solutions

- Friction-optimized deep groove ball and cylindrical roller bearings
- Other rolling bearings commonly used in electric motors, such as angular contact bearings, spindle bearings, and axial spherical roller bearings
- Aluminum oxide coating (J20) or in versions with ceramic balls for electrical insulation
- Various condition monitoring systems (OPTIME Condition Monitoring, SmartCheck, ProLink CMS)
- Optimum lubrication with automatic CONCEPT lubricators or the smart OPTIME C1 lubricator solution
- High-temperature greases such as the ARCANOL TEMP series



Products and Services

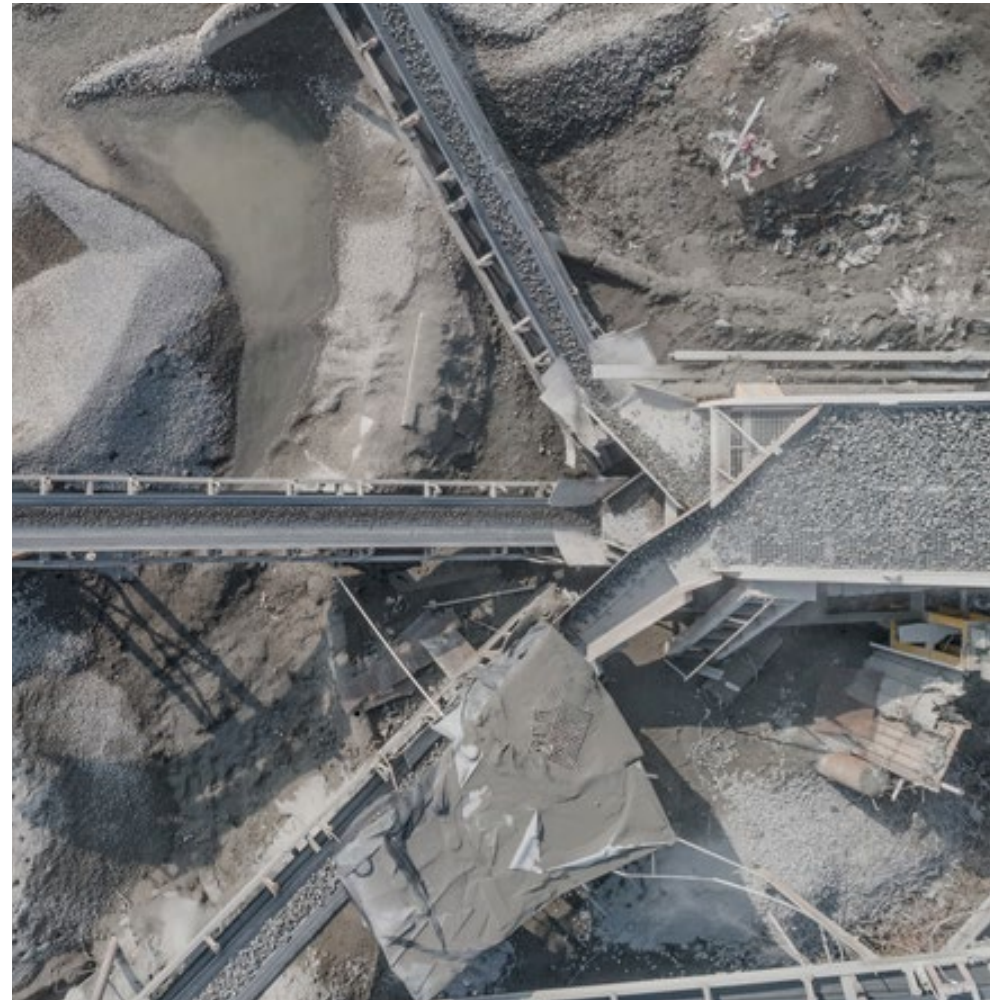

Bearing Solutions



Spherical Roller Bearings

For special loads and long service life

FAG



Designed for the highest loads, Schaeffler's spherical roller bearings are made for plants in which high stresses occur and where shaft deflections or misalignments have to be compensated. In every area of application, they are distinctive for their high performance and reliability.

X-life increases performance, cost-effectiveness, operating life, and reliability. Decisive advantages from which customers benefit include optimum kinematics, low wear, and a 60% longer service life, with low maintenance requirements and minimal costs compared to the previous standard. The versatile bearings also save space as significantly smaller bearings can easily match the performance of larger variants.



Performance increased by 50% thanks to global cooperation

One of the largest copper mines in the US wanted to increase its transport throughput by 50% – and with no structural change to the material handling systems. The Schaeffler Global Technology Network worked closely with them on this solution. As a result of this collaboration, experts from the US, Germany, and Canada not only achieved the desired increase in throughput but also improved their system availability.

One bearing, many solutions

Schaeffler offers a wide range of standard bearings, as well as the necessary expertise and infrastructure to solve a range of challenges.

- Radial spherical roller bearings, also available in sealed form

Spherical Roller Bearings with End-Profiled Rollers

The solution for bearings exposed to particularly heavy stresses

The harsh operating and environmental conditions in the mining industry and raw materials processes put extreme stress on the bearings used in these applications. In roller presses, for example, they are exposed to high grinding forces and impact loads. Service changes, which are necessary at regular intervals, quickly let dust and other contaminants penetrate the bearing. The dirt particles act like sandpaper and facilitate early material fatigue, which leads to edge loading and further accelerates wear. With end-profiled rollers, the defined removal of material helps to reduce the edge loading and thus prevents wear. The result is a significant improvement in bearing service life.

FAG

15%

The modified line contact between the rollers and races prevents harmful edge stress. This improves service life by up to 15 percent.

The switch to spherical roller bearings with end-profiled rollers helps reduce edge stress caused by abrasive material wear by up to 20 percent.

20%

**ADVANCED STANDARD
FOR SPHERICAL ROLLER
BEARINGS:
WITH BORE
DIAMETERS FROM**

**THE 241
SERIES**

400 MM*

*Also available for other bearing sizes soon.



Benefits at a glance

- Improved overload protection
- Improved service life
- Improved wear resistance
- Improved system availability
- Improved operational safety



Special Spherical Roller Bearings **FAG**

For reliable use in vibratory machines



Vibratory machines are extremely stressed aggregates that have special requirements. The most important are: higher operational reliability, prevention of shaft damage, and reduction of repair costs. Special spherical roller bearings fulfill these tasks.

Spherical roller bearings with Durotect CK coating in the bore have proved particularly effective in these situations. In particular, the coating prevents fretting corrosion between the bearing bore and the shaft. This ensures that the possibility of displacement (non-locating bearing function) between the bearing bore and the shaft, which is necessary due to thermal influences, is retained for a very long time. The coated bearings comply with DIN/ISO dimensions and tolerances. On top of this, they are replaceable.

Safety for vibrating screens

Conveying and separation technology is the specialty of Spaleck GmbH und Co. KG. Vibrating conveyors, screening machines, and customized solutions all feature in the manufacturing range of this German company, which is one of the leading suppliers in the recycling sector. Vibrating screens are of central importance in the production process. In order to prevent unplanned downtimes of these systems and the associated production gaps and costs, Schaeffler installed a SmartCheck on one shaft end of a vibrating screen. It ensures safe monitoring there.

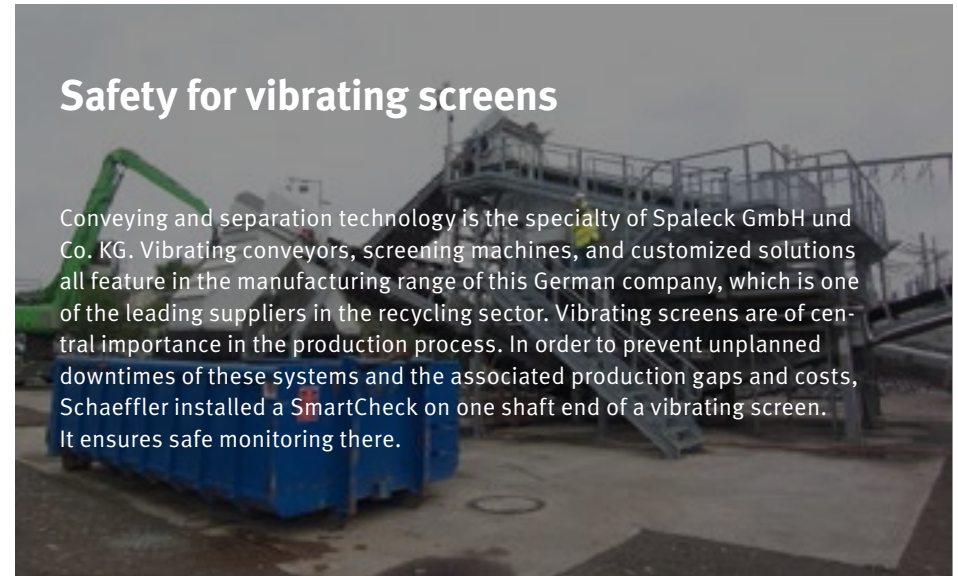

SmartCheck for smart monitoring

Ideal for the harsh conditions associated with vibrating screens. In addition to reliable and highly precise monitoring of the most important vibrating screen conditions, the compact SmartCheck stands out with its convenient operation and simple set-up.



Intelligent measuring system:
the SmartCheck

Cylindrical Roller Bearings

For heavy radial and axial loads



Able to withstand enormous forces: Our cylindrical roller bearings can withstand extremely heavy radial loads, and can also handle axial forces if they are used as support or locating bearings. Radial loads are transferred via the race, while axial loads are transferred via the rolling-element end faces and ribs.

Cylindrical roller bearings are available in a wide range of designs, dimensional ranges, and sizes to meet specific requirements. A development partnership between Schaeffler and leading machine manufacturers has resulted in a product solution for the cement industry that has since proved itself many times over: four-row cylindrical roller bearings. The advantage of this special design is a maximization of the number of rolling elements per row. The load-bearing capacity is significantly increased and at the same time a more compact design is made possible. The four-row cylindrical roller bearings can be dismantled and are particularly easy to fit. This also makes it easier to inspect the races on the bearing rings. Overall, four-row cylindrical roller bearings are an exceptionally economical and operationally reliable solution for your application.

Outstanding development capacities for high-performance machines

Rolling bearings in roller presses must meet the highest requirements and withstand heavy loads. As part of a development partnership between Schaeffler and the machine manufacturer KHD Humboldt Wedag, a special bearing arrangement concept was developed in which four-row cylindrical roller bearings are used. The load-carrying capacity is double that of spherical roller bearings and allows a more compact design overall. Consequently, it was possible to achieve a high level of performance with a high level of operational reliability and cost-effectiveness.

Large-size bearings with cages in the new TB design

All TB series cylindrical roller bearings with cages have a completely updated bearing design, which contributes directly to the advantages of TB rollers:

- Increased axial load-carrying capacity facilitates new bearing support concepts and design possibilities (downsizing)
- A higher level of energy efficiency due to the reduced frictional torque
- Lower operating costs due to reduced energy consumption
- Increased performance while maintaining the same costs
- Suitable for very high speeds

Tapered Roller Bearings

Bearings with optimum load distribution

FAG



Heavy-duty, reliable, and energy efficient: Tapered roller bearings balance loads effectively due to their bearing spacing and ensure precise and rigid shaft guidance. They have a broad speed range and are easy to adjust, disassemble, and assemble.

Tapered roller bearings with large bore diameters are used in grinding rolls, for example. Large tapered roller bearings withstand the massive radial and axial loads with equal effectiveness. They are also characterized by a broad usable range of speeds. The tapered roller bearings reliably withstand loads even under adverse conditions and ensure precise and rigid shaft guidance. The adjustability and removability of the bearings ensure easy installation and maintenance. Many of our tapered roller bearing standard series are available in X-life quality. The effect: higher load capacity, less maintenance, longer service life, and optimized overall cost-effectiveness. We also offer a wide range of flexible and individual product solutions through our concept of partnership-based development.

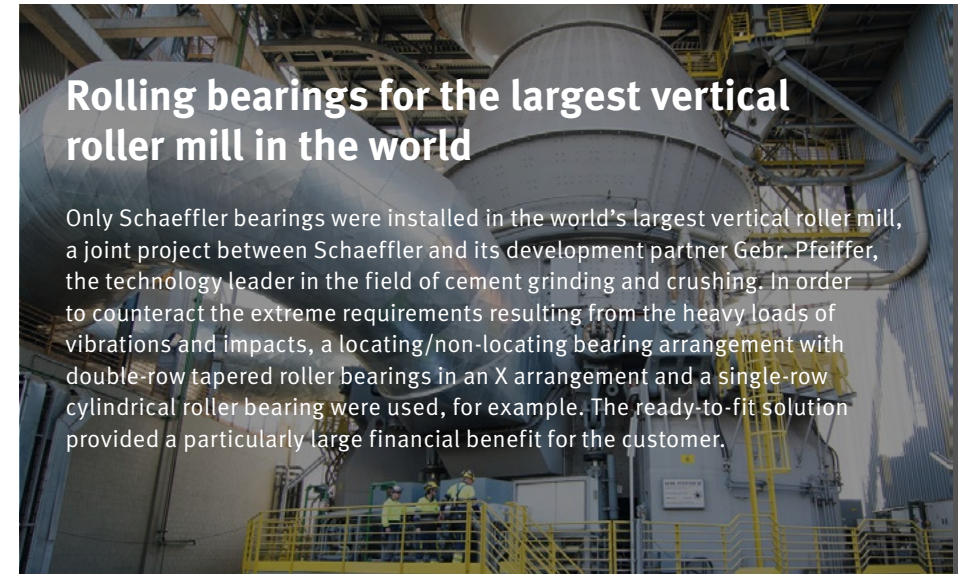

Rolling bearings for the largest vertical roller mill in the world

Only Schaeffler bearings were installed in the world's largest vertical roller mill, a joint project between Schaeffler and its development partner Gebr. Pfeiffer, the technology leader in the field of cement grinding and crushing. In order to counteract the extreme requirements resulting from the heavy loads of vibrations and impacts, a locating/non-locating bearing arrangement with double-row tapered roller bearings in an X arrangement and a single-row cylindrical roller bearing were used, for example. The ready-to-fit solution provided a particularly large financial benefit for the customer.



Customized tapered roller bearings

The customized solutions offered by Schaeffler in the form of specially adapted tapered roller bearing units offer a number of special advantages:

- The bearings are ready to fit
- Reduced installation costs for the customer and end operator
- Bearing dimensions specially adapted to customer requirements
- Maximum operational reliability
- Long life span
- Significant economic benefit for the customer

Spherical Plain Bearings (Plain Bearings)

Maintenance-free and environmentally friendly
with long service life



Spherical plain bearings feature extremely low coefficients of friction and low wear of the sliding surfaces. At the same time, they have excellent sealing. The result is lengthy service lives, easier maintenance, and a substantial reduction in maintenance overheads.

Users benefit from significant savings in maintenance costs and lubricant usage, as plain bearings are either maintenance-free or, thanks to their superior optimized sealing, significantly reduce the amount of maintenance required. Maintenance-free spherical plain bearings are self-lubricating by means of polytetrafluoroethylene (PTFE) and do not require any maintenance or lubrication. Innovative sliding materials such as ELGOGLIDE, PTFE-GFRP ELGOTEX, or the metal-polymer composite E40 significantly reduce friction in spherical plain bearings, heads, bushings, washers, and strips. Compared in terms of performance and combined with the optimized sealing, spherical plain bearings requiring maintenance offer protection against dirt, which extends the service life.

Maintenance-free spherical plain bearings for “Puente de la Mujer”

A true architectural and technical masterpiece, the “Puente de la Mujer” is a pedestrian bridge in the old port of Buenos Aires and an imposing structure with a weight of 1,093 metric tons and a length of 170 meters. Its distinctive feature is its 35 meter high pylon and a rotating function to allow water traffic to pass through. The mobile section can rotate 90°. The maintenance-free axial and radial spherical plain bearings from Schaeffler ensure that the asymmetrical design functions reliably.



Advantages of spherical plain bearings with ELGOGLIDE

- Suitable for medium to heavy loads
- No relubrication required
- No maintenance
- Low friction
- Insulating
- Impact-absorbing

Plummer Block Housings

For a balanced distribution of loads

FAG



The Schaeffler portfolio offers a wide selection of standard housings for a large number of different applications. They can also be specially configured – for example, with regard to the desired bearing type, lubrication, or sealing of the housing.

The standard housing portfolio includes split and unsplit plummer block housings. Since the upper part of the housing is removable in the split design, installation and maintenance are much easier. If harsh environmental conditions and enormous stress on the bearing arrangement are to be expected, unsplit plummer block housings should be selected for easy access to the installed bearings and seals. Schaeffler also offers special housings when standard housings can no longer satisfy all requirements in particularly complex applications.

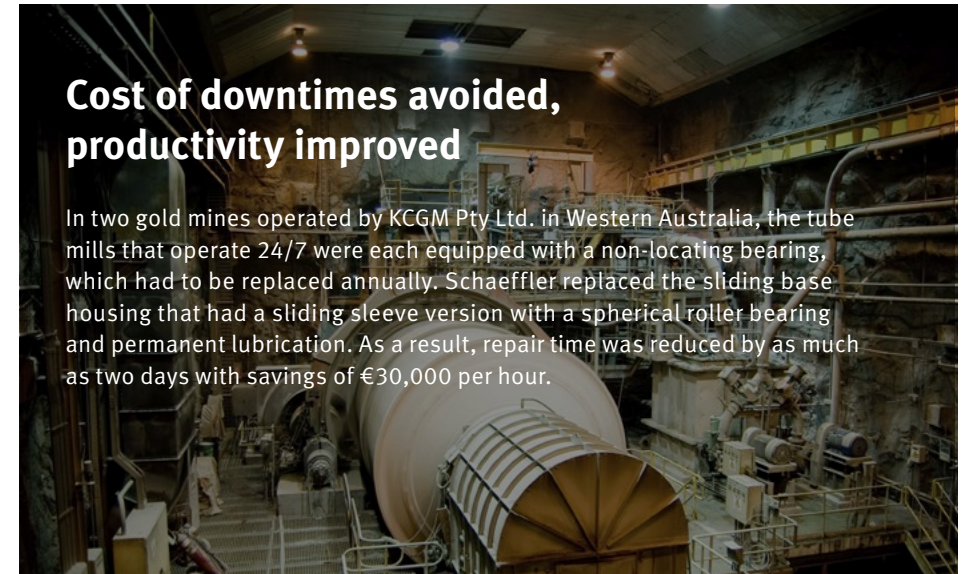

Cost of downtimes avoided, productivity improved

In two gold mines operated by KCGM Pty Ltd. in Western Australia, the tube mills that operate 24/7 were each equipped with a non-locating bearing, which had to be replaced annually. Schaeffler replaced the sliding base housing that had a sliding sleeve version with a spherical roller bearing and permanent lubrication. As a result, repair time was reduced by as much as two days with savings of €30,000 per hour.

Housing types for the cement industry

- Split housings
 - SES for shaft sizes up to 140 mm
 - SNS for shaft sizes from 140 mm
 - RLE for 241 series spherical roller bearings
 - LOE, especially for oil lubrication
- Unsplit housings
 - BND for especially high loads



SES housing with split spherical roller bearing

Split Spherical Roller Bearings

For short downtime and easy maintenance



Split bearings shorten downtimes in the event of bearing replacement and massively reduce the associated costs. They are mainly used where the replacement of unsplit bearings would require time-consuming additional work, such as the dismantlement of drive systems or removal of gears.

Split spherical roller bearings have a cylindrical bore. They are generally fitted in place of unsplit spherical roller bearings with an adapter sleeve. The inner and outer rings and the cage with roller and cage assembly are separated into two halves. The bearings are hinged in the middle and the affected half can be removed. This reduces the amount of maintenance required. In terms of purchase, split pendulum tube bearings are a greater investment compared to the unsplit ones. However, such an investment will pay for itself very quickly through reduced assembly costs and shorter system or machine downtime. Unsplit spherical roller bearings can be replaced by split spherical roller bearings of the same dimensions.

Fast replacement with no downtime

The drive end bearing in the main ore conveyor system at Australia's largest mine had to be replaced urgently. Because the drive system had not been touched for a long time, the operator, BHP Billiton Base Metals, faced a costly break in production. A split spherical roller bearing enabled a significant reduction in overhead costs and avoided an unscheduled interruption to operations.



Technical and financial advantages

Savings: The installation of split spherical roller bearings reduces machine and system downtimes and significantly lowers installation costs.

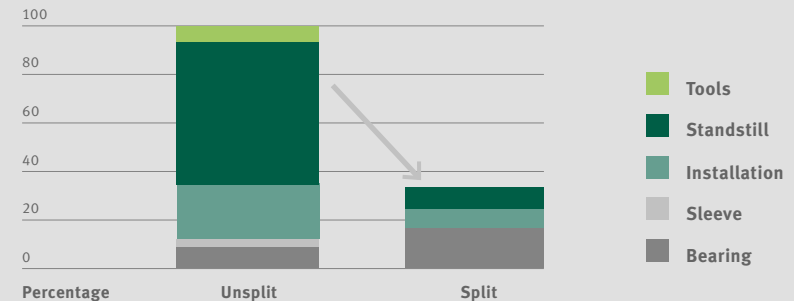

Axial Spherical Roller Bearings

For very heavy axial loads and high speeds



Axial spherical roller bearings are single-row roller bearings with an angular adjustment capability. They consist of solid shaft and housing locating washers and asymmetrical barrel rollers with cages that hold the roller and cage assembly together with the shaft locating washer.

Axial spherical roller bearings absorb very high axial loads and enable relatively high operating speeds, even under the harshest environmental conditions. The bearings can be disassembled, which means the bearing components can be fitted separately. A range of sizes are available in the X-life version. This quality seal guarantees features such as maximum lifespan and service life, and the best load capacity even at maximum speeds. The higher dynamic load ratings compared to conventional versions open up new design opportunities for axial spherical roller bearings in X-life quality. That means they are ideally suited for downsizing, for example.

Spherical roller bearings provide shade in Wimbledon at the push of a button

At Wimbledon's Centre Court, more than 300 spherical roller and axial spherical roller bearings ensure that the roof with a span of 77 meters opens or closes in just a few minutes. Like an accordion, the 5,200 square meters of fabric can be folded to save space. Several arched trusses in the roof halves bridge the playing field and stands, and give the roof stability. Axial spherical roller bearings support the loads of up to 60 metric tons that emanate from the tension cables used to keep the truss arches and roof fabric taut.

The highest performing bearings on the market

- 45% longer service life
- 12% higher dynamic load rating
- 4% higher static load rating
- Up to 20% less friction
- 14% higher fatigue limit load
- 7% higher speeds

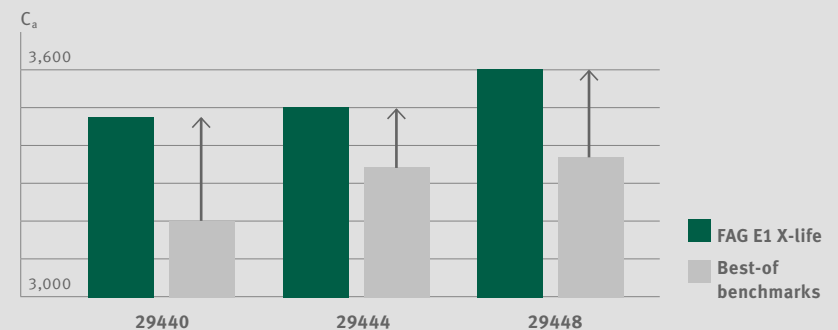

Axial Cylindrical Roller Bearings

FAG

For high load capacity with low overall height



Axial cylindrical roller bearings are a combination of axial cylindrical roller cage assemblies, housing locating washers, and shaft locating washers. The bearings have a very low axial section height, high load capacity, and high rigidity and can support axial forces in one direction. This application is advisable at high speeds, for example.

Single- and double-row axial cylindrical roller bearings are particularly suitable where high axial and impact loads act on one side but there are no radial loads. They are also an excellent choice when the load-carrying capacity of corresponding axial deep groove ball bearings is no longer sufficient. In contrast to the ball, the roller has a larger contact area perpendicular to the roller axis. As a result, it can transmit higher forces, is stiffer, and tolerates smaller rolling elements for the same load in diameter. That makes axial cylindrical roller bearings ideal in very small axial spaces. As standard bearings, they are also a low-cost alternative to self-configured bearing concepts.

Available complete or in components

Axial cylindrical roller bearings are recommended for special loads such as high speeds. In addition to complete single- and double-row axial cylindrical roller bearings, the following individual bearing parts are alternatively offered for combination:

- Axial cylindrical roller and cage assembly
- Housing locating washer
- Shaft locating washer
- Bearing washer



Recommended cages

Solid cages made of brass and polyamide PA66 are the standard for axial cylindrical roller bearings. Brass cages are preferred for continuously high temperatures and applications with difficult operating conditions. The cage design depends on the bearing series and size. Axial cylindrical roller bearings with a brass or polyamide PA66 cage can be used in a wide range of temperatures. Temperatures from $-20\text{ }^{\circ}\text{C}$ to $+120\text{ }^{\circ}\text{C}$ are possible.

Deep Groove Ball Bearings

For low-friction, reliable operation

FAG



Deep groove ball bearings are versatile, self-retaining bearings. These bearings, with a simple design, high resistance, durability, and low maintenance, are available in different variants: single-row or double-row, open or sealed design, and unidirectional and bidirectional.

Single-row deep groove ball bearings are designed for high speeds and can accommodate both radial and axial forces. If a large radial load-carrying capacity is required for which single-row deep groove ball bearings are not sufficient, the double-row variants are the best choice. They can be subjected to higher loads because of the larger number of rolling elements. Since the bearings also support loads caused by tilting, they are suitable for particularly short shafts that are only to be supported by one bearing. Deep groove ball bearings are especially used in electric motors for driving industrial pumps and fans in mining.

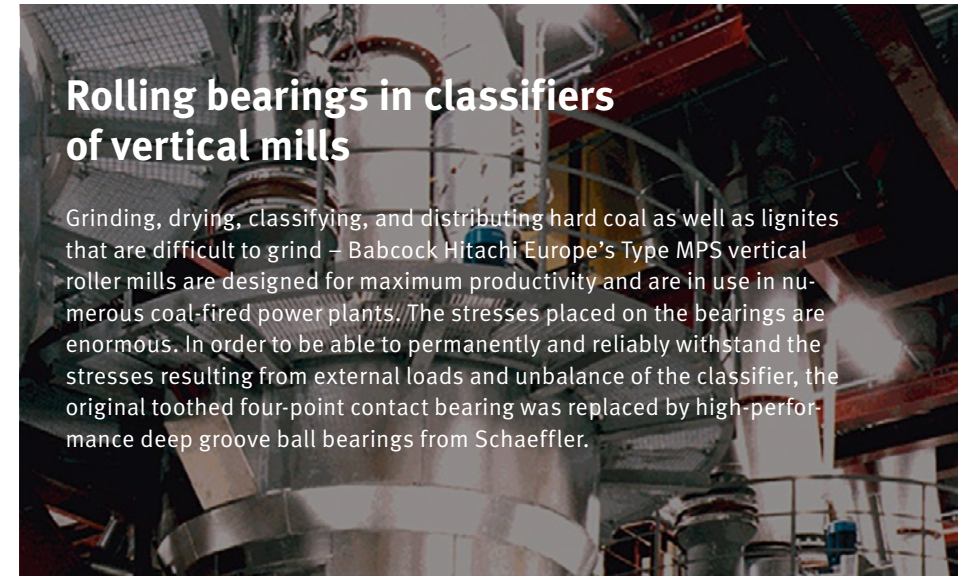

Rolling bearings in classifiers of vertical mills

Grinding, drying, classifying, and distributing hard coal as well as lignites that are difficult to grind – Babcock Hitachi Europe's Type MPS vertical roller mills are designed for maximum productivity and are in use in numerous coal-fired power plants. The stresses placed on the bearings are enormous. In order to be able to permanently and reliably withstand the stresses resulting from external loads and unbalance of the classifier, the original toothed four-point contact bearing was replaced by high-performance deep groove ball bearings from Schaeffler.



Generation C deep groove ball bearings

More durable, quieter, lower friction

- Refined manufacturing processes
- Reduced amount of noise generated
- Improved osculation and less friction
- Optimized bearing kinematics
- Improvement of cage roundness, waviness, and roughness
- High sealing effect without friction losses

Lifetime Solutions

- >
- >
- >
- >
- >
- >
- >
- >
- >
- >



SmartCheck

Online measuring system for decentralized machine monitoring



The SmartCheck is a compact, innovative, modular on-line measuring system for continuous, decentralized monitoring of machinery and process parameters. The system is particularly attractive for assemblies where monitoring was previously too cost-intensive.

Companies often forgo continuous monitoring of standard units such as pumps, motors, and gearboxes for cost reasons. SmartCheck changes this. The system offers the same performance features as expensive monitoring systems, but is compact, easy to install, and easy to operate. The power, speed, and temperature of multiple motors can be viewed in a Web browser after installation and set-up. Alarms go off if a limit is exceeded. In addition, a connection to the control system or the control station is possible using analog and digital interfaces. SmartCheck can be expanded on a modular basis. This means that the system can be adapted at any time as requirements change.

Investment protection through continuous vibration monitoring

Vibration monitoring with SmartCheck on a roller mill was discontinued because no critical values had been noticed in four months. Three months later, some outer ring damage was spotted. A re-examination of the measurement data showed that if the monitoring had been continued, an alarm would have been triggered in time and high follow-up costs could have been avoided.

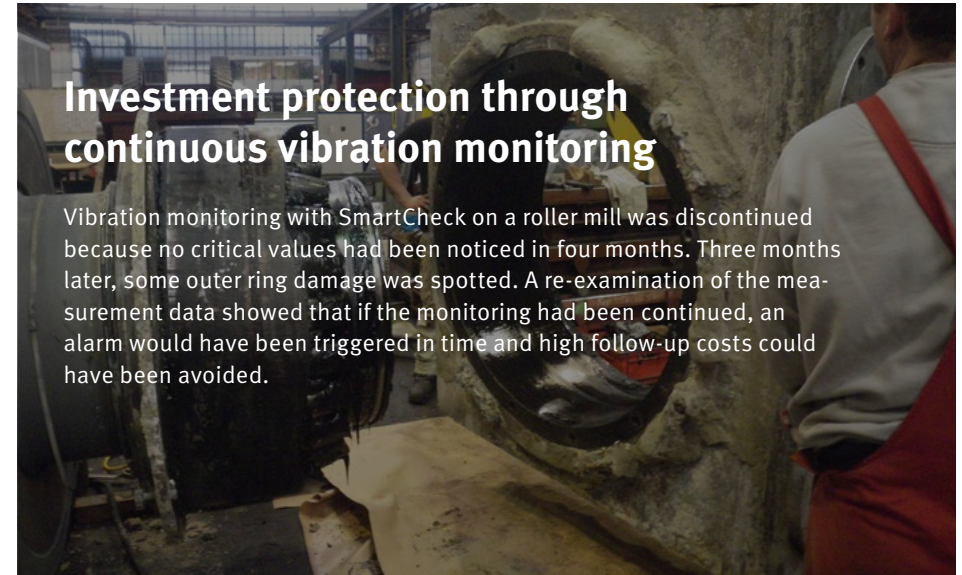

Function

The device can be connected to the control system or the control station using analog and digital interfaces, for example.



OPTIME Ecosystem

Easy in every way

Consisting of award-winning solutions for both condition monitoring and smart lubrication, the OPTIME Ecosystem reduces unplanned downtime by making predictive maintenance easy for the process industry. Here is an overview of the ecosystem's elements and how they work together.

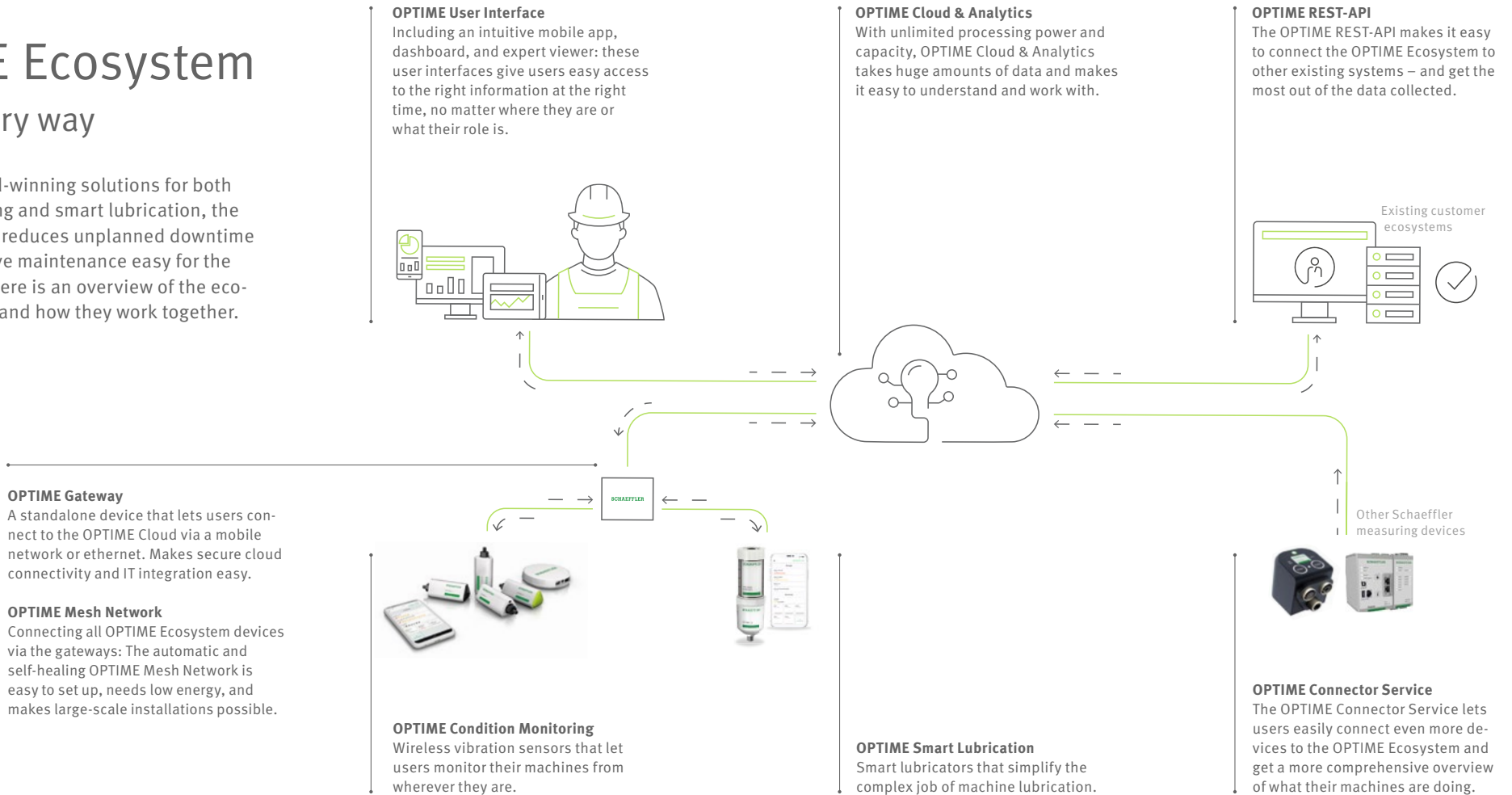

OPTIME Condition Monitoring

Plug. Play. Predict.



Condition monitoring can be expensive. Which is why up to 95% of all machines inside factories are only sporadically monitored – or not at all. This can lead to breakdowns and unplanned downtime.

Schaeffler's OPTIME Condition Monitoring solution helps eliminate such downtime thanks to wireless vibration sensors that can detect potential damage, imbalances, and misalignments weeks in advance. Its simple plug-and-play functionality means installing it takes mere minutes – no prior experience required. This allows entire plants to be monitored in just a single day.

The wireless condition monitoring solution also works with almost all machines – and is more affordable than most other condition monitoring solutions. And scaling up is always possible as additional vibration sensors can be easily added at any time.

Comprehensive monitoring

Finnsementti, a cement manufacturer in Finland, opted for Schaeffler's OPTIME Condition Monitoring to reduce unplanned downtime. Using the wireless solution, the cement manufacturer could monitor almost all rotating machines in their plant quickly, precisely, and continuously. About 150 sensors were installed on motors, fans, pumps, and gearboxes and installation took just a few hours.

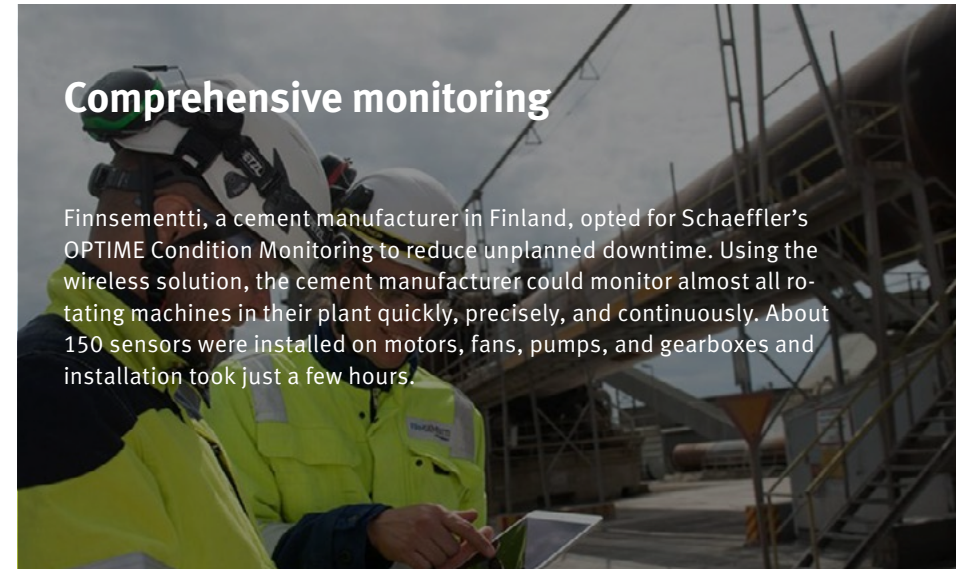

OPTIME Ecosystem

Easy in every way



Consisting of award-winning solutions for both condition monitoring and smart lubrication, the OPTIME Ecosystem reduces expensive downtime by making predictive maintenance easy for the process industry.

OPTIME C1

Turn complexity into simplicity



The world is complex. And so is the job of a maintenance manager. And part of that complexity comes from the truly insignificant things. The tasks they wish they could cut out of their daily routines – but can't. Because there's been simply no better way of doing it. Not till now at least.

Combining all the benefits of automatic lubrication with award-winning smart technology: the OPTIME C1 is the world's first truly smart lubricator and eliminates tasks such as lubricating by hand. Such as having to manually check many lubrication points. Instead: all the maintenance manager needs to do to check on the status of their lubrication points is to check the app – from wherever they are.

With an extremely intuitive interface, the OPTIME C1 will tell the user which lubrication points are insufficiently supplied and which cartridges need to be refilled or replaced. Thus eliminating premature bearing failure caused by insufficient and/or incorrect lubrication – and eliminating downtime.

Simplification in action

Founded in 1916, Westerwälder Elektro OSMOSE is a manufacturer of ceramic products for the building, water, and wastewater industries. By using the OPTIME C1 in their plants, the company was able to avoid downtime that would have generated costs of €47,000. With its smart functionality, the OPTIME C1 helps OSMOSE's maintenance managers keep an eye on the fill level of their lubricators and warns them of any impending lubrication shortage – thus saving time and money.

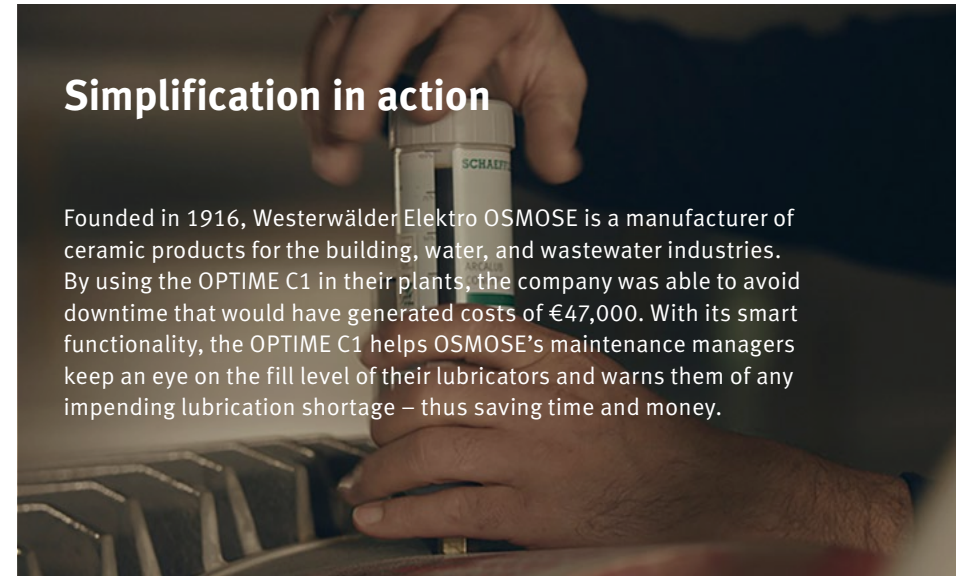

OPTIME Ecosystem

Easy in every way



Did you know that the OPTIME C1 is part of a larger ecosystem that helps reduce expensive downtime? Find out more.

CONCEPT1–8

Precise, automatic grease and/or oil lubrication



Almost all bearings can be supplied with precise amounts of oil or grease using the automatic lubricators in the CONCEPT series. The range covers single-point devices for entry-level automatic lubrication and complex solutions that can even be integrated into control systems.

The CONCEPT1–8 electrochemical lubricators offers a low-cost and versatile solution for supplying equipment with grease or oil. The lubricant is dispensed by gas pressure built up by means of an electrochemical drive unit. CONCEPT2, CONCEPT4, and CONCEPT8 are electromechanical lubricators and are used for more complex requirements, such as when there are a large number of different lubrication points. They differ in the number of outlets (2, 4, and 8), in whether grease or oil is used, and in whether the dispensing process is to be triggered by internal pulses, for example.

Automatic lubrication in a dusty environment

The production of calcium hydroxide is a dusty business. To ensure reliable lubrication even in this setting, a company called VSCL in the Philippines switched from manual to automatic lubrication. The CONCEPT1 automatic lubricator substantially improved lubrication quality, and simultaneously greatly reduced the effort needed to service hard-to-access lubrication points.



Advantages at a glance

- Lubrication for almost all systems
- Premium lubricants
- Future-oriented expertise
- Flexible programmability

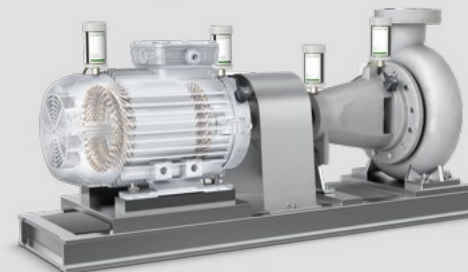

ARCANOL

Lubricants for every application



Perfectly matched lubrication increases the performance and service life of a rolling bearing immensely. With ARCANOL, Schaeffler developed a lubricant range that is divided into four different application groups, covering almost all areas of application.

The ARCANOL grease range includes multi-purpose, heavy-duty, high temperature, and specialty greases and currently features 22 different lubricant grades in up to eight different container sizes. ARCANOL greases generally have better characteristics than regular greases. The respective composition was analyzed and tested for each individual application area using modern processes and systems under different operating conditions and with rolling bearings of all designs. They are subjected to a new quality inspection before delivery. This means that there is clear evidence of the quality of each batch. Assembly paste and corrosion protection oil complete the lubricant portfolio.

10% longer service life with the right grease

A major Peruvian copper producer switched to the high-quality ARCANOL LOAD1000 grease for its high-pressure grinding rolls in open-pit mining. It is more resilient and higher-yielding than the lubricants previously used. By switching to ARCANOL, the company now saves several tons of grease annually. In addition, a sustainable contribution is made to the preservation of the environment.



Advantages at a glance



- Lubricant matched to the application
- Consistent, high quality standard
- Extended rolling bearing life
- Great savings in grease consumption

Accessories and Services for Lubrication

Manual lubrication tools and more



The optimized lubrication portfolio is complemented by accessories for automatic lubricators, manual lubrication tools, customized lubricant cartridges, and assembly pastes, as well as oil for corrosion protection.

If automatic lubrication is not possible or not desired, the optimal amount of grease can be applied with grease dispensing guns or grease pumps and other tools from Schaeffler during manual lubrication. The mounting paste facilitates the sliding of bearing rings and prevents stick/slip effects, scoring, wear, and fretting corrosion. It also provides protection against corrosion. The paste can be used at temperatures between $-30\text{ }^{\circ}\text{C}$ and $+150\text{ }^{\circ}\text{C}$. It is resistant to water, steam, and many alkaline and acid agents. Anti-corrosive oil protects all bare metal surfaces, for example on equipment and machinery, and especially unpacked bearings when stored indoors.

Services for lubrication

Lubrication prevents or reduces contact between the rolling and sliding surfaces, protects against corrosion, and seals at the same time. Our services start with recommendations for suitable lubricants and systems, continue with the development of recommendations for action, and end with comprehensive analyses of the lubricants in use.

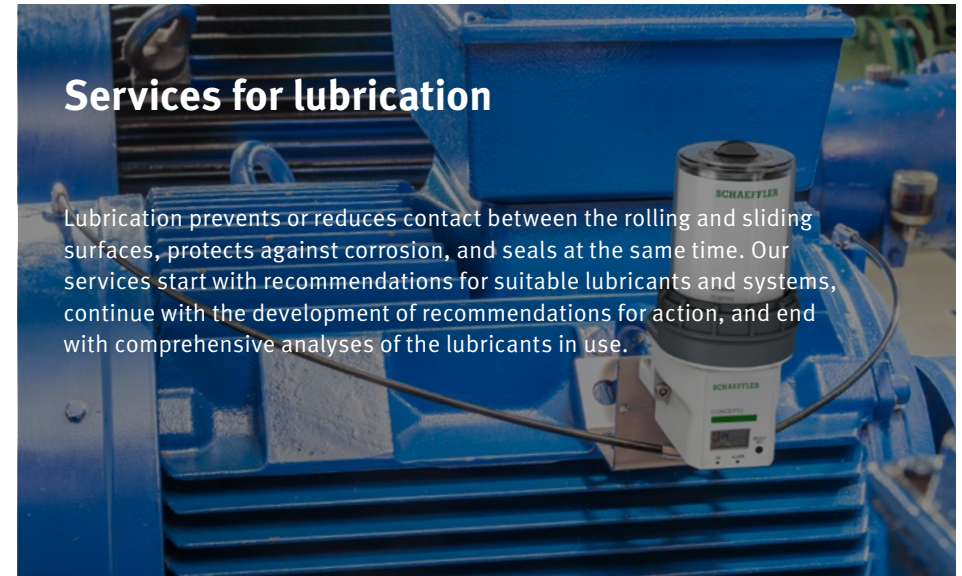

Comparison: Wear with and without lubrication

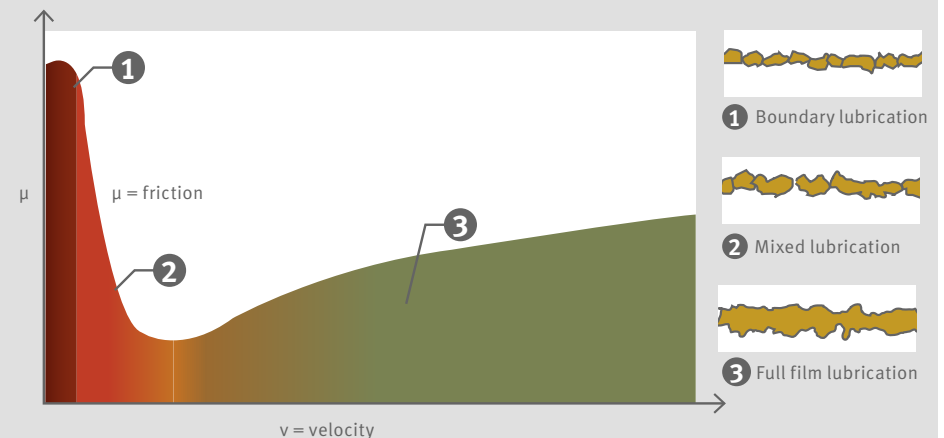

GreaseCheck

Optical measuring system for condition monitoring for greases



Changes in a grease's condition can be detected with GreaseCheck long before damage from vibration changes becomes measurable. This allows lubrication to be planned precisely. The customer is free to decide whether to relubricate or replace the grease completely.

GreaseCheck is a self-sufficient, maintenance-free, optical measuring system. It consists of a grease sensor and an evaluation unit. The sensor has analog, digital, and CAN bus interfaces. They can be used to monitor grease contamination, consistency, and water content during operation. This information is transferred by cable to the evaluation unit which in turn generates an analog signal that provides the user with information about the condition of the grease rapidly and easily. This enables maintenance teams to perform grease relubrication based on actual demand. There is no need for time-consuming calculations of the lubrication quantity or unnecessary relubrication.

Integrated bearing and service solution for converters

A leading steel manufacturer planned to increase the capacity of its two converters and now relies on an integrated Schaeffler solution. The converter status is monitored using a combination of different methods, which means acoustic emissions, vibrations, and the lubricating greases are analyzed. GreaseCheck is used to prevent unplanned downtime due to bearing damage.

Extended warning time with GreaseCheck

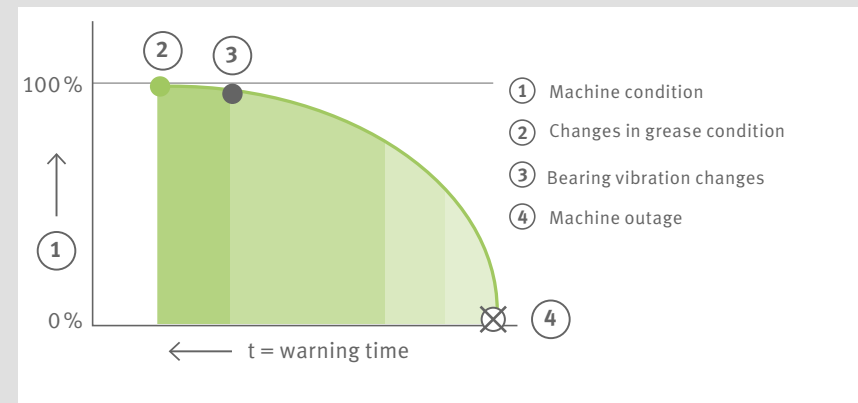

LASER-EQUILIGN2

For precise and cost-effective shaft alignment



Designed for aligning rotating shafts to avoid downtime: With its single-laser technology, the LASER-EQUILIGN2 alignment system offers maximum user-friendliness, precision, energy, and cost efficiency.

Interrupted processes increase the cost of any operation. If rotating shafts are not correctly aligned, they can result in unintentionally high vibrations, temperature increases, energy consumption, and therefore downtime. LASER-EQUILIGN2 helps to avoid unplanned downtime. This is because it improves the alignment of the shafts of pumps, compressors, and gearboxes with each other. This innovative laser system lets machine performance and plant availability be increased while reducing operating costs because rotating shafts are perfectly aligned with LASER-EQUILIGN2.

One laser to combat downtime

Approximately 60 percent of all unplanned downtime in production plants is attributable to unbalance and misalignment. Such incidents can be avoided with the LASER-EQUILIGN2 shaft alignment device.

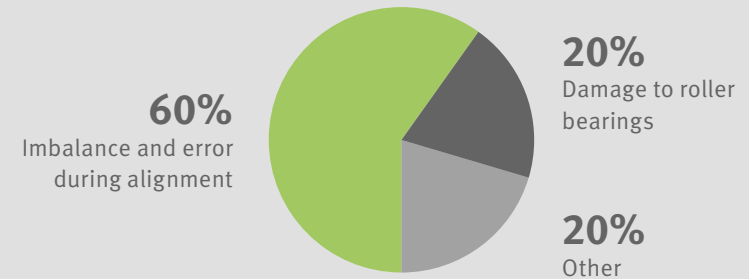

Sample calculation: Lowering electricity costs

Precise alignment with LASER-EQUILIGN2 significantly reduces operating costs. This example shows the savings resulting from 1% lower power consumption by six machines running at 75 to 200 kW (running time 8h/day).

Motor power	75 kW	100 kW	200 kW
Annual energy cost	€37,440	€49,920	€99,840
Expected energy reduction	1%	1%	1%
Saving per machine	€374	€499	€998
Saving with six machines	€2,244	€2,994	€5,988

MF-GENERATOR

Induction systems with medium frequency technology for large components



Induction systems with medium frequency technology (MFT) is used to heat rolling bearings so that they can be easily installed or removed. The plant consists of a generator and – depending on the requirements – a fixed or flexible inductor, which is placed on the workpiece.

Medium frequency technology systems can also be used for thermal assembly and disassembly, and can significantly reduce energy costs. With an efficiency of over 90%, they are significantly more energy-efficient than conventional heating devices. The compact systems can even be used in areas that are difficult to access. In all devices for heating, the temperature can be adjusted up and down continuously.

More than €300,000 saved thanks to a high-performance heating device

With an installed production capacity of five million metric tons of cement per year, Asia Cement Public Company Limited is one of the largest cement producers in Thailand. Previously, this customer usually needed about 30 days to overhaul a large raw material mill gearbox. The highly efficient Schaeffler heating device with medium-frequency technology and flexible inductors was used to accomplish this overhaul faster and more economically. It achieved its goal despite the very large components that had to be warmed up for removal and installation.



MFT functionality principle

1. Short-circuit current I_R in the bearing ring
2. Alternating magnetic field
3. Bearing ring
4. Exciter coil

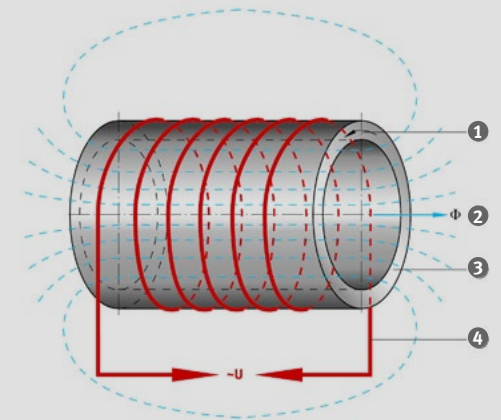

HEATER

Inductive heat for precise and sustainable assembly



Sealed and greased spherical plain bearings can also be heated with the HEATER induction heating devices for spherical plain bearings with a mass of up to 1,200 kg. In addition to the regular HEATER tabletop and floor-standing units for larger warehouses, HEATER devices can also be upgraded to a mobile version.

The HEATER product line is available in two series. The BASIC series has all the necessary basic functions for induction heating and is suitable for harsh ambient conditions. The HEATER BASIC units are available in either table-top or floor standing configurations for a maximum rolling bearing mass of up to 1,600 kg. The SMART models have a delta-T control system, which is recommended for rolling bearings with low radial clearance. They can precisely document the heating process, which can be important for particularly safety-relevant applications, for example.

Heat for the heavy-weight class

Industrial companies in all parts of the world use TAKRAF bucket wheel excavators, spreaders, crushing plants, belt cars, reclaimers, leach pads, and processing plants for their applications. A relatively young product field, TAKRAF developed roll crushers including the corresponding gearboxes. These gearboxes consist of large and heavy components weighing up to 5,000 kilograms. The FAG HEATER 5000 was developed for this massive challenge. In addition, an entirely new technology was used with the delta-T control system.



Available heating methods

HEATER BASIC

- The temperature mode (controlled heating)
- The time mode (serial heating without temperature sensor)

HEATER SMART

- The temperature mode (controlled heating)
- The time mode (serial heating without temperature sensor)
- The time and temperature mode (select target temperature or heating time)
- The temperature and velocity mode (with maximum temperature gradient per time unit)

Hydraulic Pumps

For simple installation and removal of rolling bearings in conjunction with hydraulic nuts



Comfortable work with little force required for assembly and disassembly. Hydraulic hand and foot pumps are used for the installation or removal of rolling bearings in conjunction with hydraulic nuts to pressurize them.

The pumps are also used for the installation and removal of roller bearings with a tight fit, as well as other rotary machine elements where oil is pressed between the fitting surfaces for widening. The risk of bearing damage is significantly reduced because the components and rolling bearings can be precisely positioned by defining a starting pressure. The hydraulic pumps are available in different versions, which can be manual or air-operated. There is a perfectly fitting variant for almost every application.

Hydraulic pump design variants

Schaeffler supplies its hydraulic pumps as complete hydraulic pump sets. They consist of the pump body (hand or foot pump), an analog pressure gauge, a hydraulic hose (with plug-in coupling sleeve), and plug-in coupling nipple with G 1/4 thread for the consumer. The range includes the following designs:

- PUMP700-2L – manual pump, two-stage
- PUMP1000-2,2L – manual pump, two-stage
- PUMP1000-5L-AIR – foot pump, air-powered, continuously variable stages
- PUMP4000-1,6L – hand pump, single-stage



Advantages at a glance

- Work can be done comfortably with minimal force being required
- Risk of damage to rolling bearings is reduced
- Allows precise positioning of rolling bearings
- Oil can easily be refilled
- A digital measuring gauge can be used to monitor the drive-up distance
- Options for surface pressures of up to 200 N/mm²
- Wide range of accessories available

Hydraulic Nuts HYDNUT

For strong contact forces



If a lot of force is needed when assembling and disassembling bearings, hydraulic tools such as hydraulic nuts can be valuable tools. When fitting and removing large-size bearings and machine components with a conical bore, they are the first choice.

The application of hydraulic nuts such as HYDNUT..-E and HYDNUT..-E-INCH involves pressing rolling bearings or other ring-shaped components with a conical bore onto a conical seat. They are used mainly when significant force is required and cannot be achieved with pressure screws. In addition, it is easier to set the radial internal clearance for bearings. The hydraulic nut can also be used for disassembly if fastening withdrawal sleeves or adapter sleeves. The HYDNUT..-HEAVY hydraulic nut is ideal for assembling press-fit assemblies where very high drive-up forces are required for gears, shaft couplings, crushers, and roller presses, for example. The HYDNUT..-HEAVY variant is also suitable for special applications, such as those without threads on the shaft or sleeve.

Advantages of measuring displacement during mounting

Simplified installation: To be able to measure the internal clearance using a feeler gauge, there must be sufficient space for the feeler gauge and the technician's hand. When using a dial gauge, even confined spaces are no longer a problem.

Safety and accuracy: Correct measurement of the internal clearance using a feeler gauge requires a great deal of experience. The risk of incorrect measurements is almost eliminated when measuring the displacement using a dial gauge.

Correct installation of sealed bearings: The radial clearance measurement using a feeler gauge is also possible for the sealed rolling bearing designs, the seal of which can be removed. However, there is a risk of contaminating the grease and damaging the seal. Both of these factors significantly reduce bearing life.

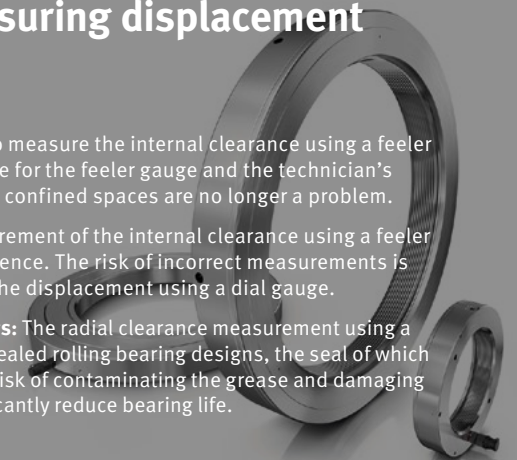

Abbreviation Name	Format	Application
HYDNUT50-E to HYDNUT200-E	With DIN 13 metric fine thread	Standard adapter and withdrawal sleeves with metric dimensions, shaft journals with metric thread
HYDNUT205-E to HYDNUT1180-E	With DIN 103 trapezoidal thread	Standard adapter and withdrawal sleeves with metric dimensions, shaft journals with metric thread
HYDNUT50-E-INCH to HYDNUT950-E-INCH	Standard adapter and withdrawal sleeves with metric dimensions, shaft journals with metric thread	Shaft journals or sleeves with inch-based thread
HYDNUT100-HEAVY to HYDNUT900-HEAVY	Reinforced finish without thread	For heavy mounting forces, e.g., shipbuilding

Mechanical Tools

For professional assembly, disassembly, and maintenance



Mechanical tools are indispensable for mounting, dismounting, and maintaining bearings. The Schaeffler portfolio includes tools that cover all life cycle phases of the rolling bearing while taking into account the total costs for the customer.

For all assembly and maintenance work, it is important to keep the necessary downtimes of the production operation as short as possible. The work must be fast, without quality and safety taking a back seat. Schaeffler's high-quality transport and assembly tools, extraction solutions, and installation tool sets, as well as socket wrenches and hook wrenches provide the prerequisites for completing all activities efficiently and maximizing system availability for customers.



Mounting tool sets

for mounting small rolling bearings gently



Transport and mounting tool

for lifting and transporting large bearings by crane safely



Socket and hook wrenches

for tightening and loosening locknuts efficiently



Three-section extraction plates

for extraction without damage – by gripping the bearing directly on the inner ring and transmitting the extraction force via the rolling elements



Mechanical extractors

for dismantling bearings and bearing inner rings, and other components cost-effectively

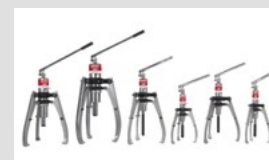

Hydraulic extractors

for dismantling bearings, and bearing inner rings even if high extraction forces are required, and for disassembling other components

Remanufacturing of Bearings

Sustainable option to extend service life



Bearings are often replaced even though they can be restored to as-new condition through proper remanufacturing. In general, the costs for such remanufacturing are significantly lower than the costs of a new bearing – with shorter delivery times in most cases.

Schaeffler carries out the remanufacturing in compliance with and control of all norms and standards worldwide. Before remanufacturing, the bearing is professionally dismantled, cleaned, and examined. Once the damage analysis is complete, the necessary work steps for restoration are determined and a quotation is prepared. Like new bearings, the remanufactured bearings pass through the accredited Schaeffler test laboratories. This service is currently used primarily by the rail and aviation industries, but is also being considered for manufacturing, which uses bearings with larger diameters. Here, too, service can significantly reduce life cycle costs.

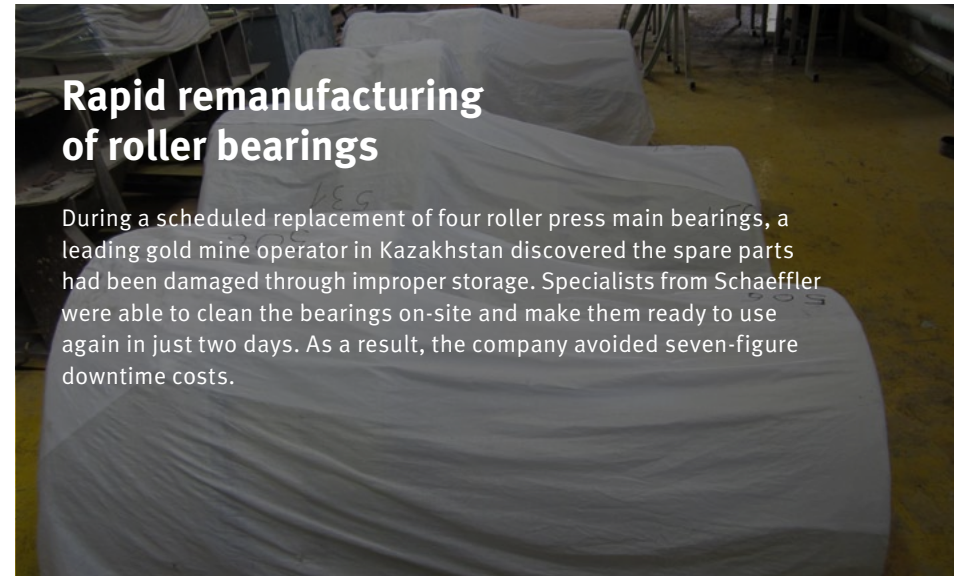

Rapid remanufacturing of roller bearings

During a scheduled replacement of four roller press main bearings, a leading gold mine operator in Kazakhstan discovered the spare parts had been damaged through improper storage. Specialists from Schaeffler were able to clean the bearings on-site and make them ready to use again in just two days. As a result, the company avoided seven-figure downtime costs.

The four levels of remanufacturing

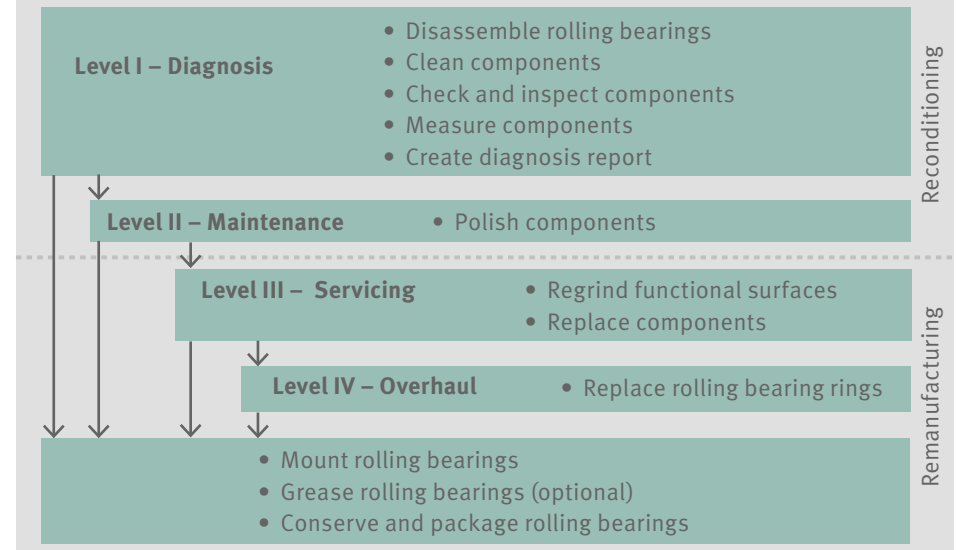

Customer Success Stories



Gebr. Pfeiffer

Gebr. Pfeiffer is one of the technology leaders in the field of cement grinding and hard comminution. As a development partner of Gebr. Pfeiffer, Schaeffler's core rolling bearing components play a key role in the functioning of the company's plants.



Challenges

The world's largest vertical roller mill, MVR 6700 C-6 in Barroso (Brazil), is state of the art and fully equipped with Schaeffler rolling bearings, including in the heart of the plant: the grinding rollers. The stresses placed on grinding roller bearings are generally extremely high, since they have to withstand very heavy loads, vibrations, and impacts. Long bearing service lives require good lubrication conditions and put high demands on the lubricant. Grinding dust, process heat, and strong flow conditions in the plants present extreme challenges for the sealing of the grinding rollers.

Solution

- Analysis with the in-house calculation program BEARINX to define the operating clearance for the bearing arrangement, taking into account manufacturing tolerances and the system's operating conditions
- Filtering of the lubricant and regular inspection ensure the quality of the bearing lubrication
- Sealing air and additional sealing rings ensure reliable sealing of the bearings
- Tailor-made design – maximum load-carrying capacity for the bearings in the specified ambient design of the customer
- Maximum load rating and performance due to pin cage or X-life quality

Technical data

- Grinding roller diameter 2,500 millimeters
- Grinding roller speeds up to 45 min⁻¹
- Loads on individual grinding roller bearings
- V1 to 2,800 kilonewtons
- Axial loads up to 300 kilonewtons
- Nominal life min. 80,000 hrs.



Customer's financial benefits

- Bearings are ready to fit – this means reduced assembly effort for the customer and end operator
- Bearing dimensions specially adapted to customer requirements
- Maximum operational reliability
- Long life span

KHD Humboldt Wedag

With over 160 years of experience in the cement industry, KHD is a leading global supplier of technology, equipment, and services for cement plants.



Challenges

Since the 1980s, roller presses have increasingly replaced ball mills, since they have a significantly higher efficiency and greater material throughput for grinding tasks in raw material preparation. The development and enhancement of high-performance roller presses places the highest requirements on the bearings used. In a development partnership between Schaeffler and KHD Humboldt Wedag, a highly efficient bearing concept was developed that was perfectly adapted to the general conditions.

Solution

The central element of the solution concept is the use of separable four-row cylindrical roller bearings. Drilled-through rollers and pin cages make the largest possible number of rolling elements per row possible, as well as a high radial load-carrying capacity. Due to the four-row cylindrical roller bearings, a radial load-carrying capacity more than twice as high as that of spherical roller bearings can be achieved with the same overall structural height. The overall concept also provides for a clear separation of radial and axial force transmission, the latter being achieved by two axial spherical roller bearings in an X arrangement. The rotational irregularity is transferred by the belt drive to all the engine auxiliary assemblies.



An overview of all the advantages

- High radial load-carrying capacity
- Optimal cross section utilization
- Angular adjustability and optimum pressure distribution in the bearing
- Locating bearing and non-locating bearing function
- Easy assembly, disassembly, and diagnostics
- Long life span

Compañía de Minas Buenaventura

Compañía de Minas Buenaventura is one of the leading companies in the mining industry in Peru – active in the four core areas of mining, processing, development, and exploration of gold, silver, and other metals.



Challenges

The company purchased a used tube mill, which was delivered in individual parts. The delivery included four new spherical roller bearings with an outside diameter of over 1.5 meters. The installation of these bearings is very complex. Incorrect assembly or damage to the conversion elements can lead to an unplanned shutdown of the system and therefore to production losses. Since the customer had no experience whatsoever with the mounting of large bearings, it turned to Schaeffler.

Solution

Experienced assembly specialists from the Schaeffler Technology Center in Sorocaba worked closely with the mill operator's suppliers. In addition, the team in Peru was supported by the Schaeffler Grinding Mills Competence Centre based in Melbourne, Australia. The Schaeffler technicians also provided detailed information on the process to ensure that the rolling bearings were mounted correctly on the journals. This good cooperation demonstrates the close networking of Schaeffler specialists worldwide as well as their extensive industry-specific experience in the mining sector. Thanks to the competent support of the Schaeffler specialists, the rolling bearings were mounted quickly and successfully. The risk of unplanned bearing damage due to faulty

assembly was thus reduced for the customer. Such failures can lead to a two- to three-day plant shutdown with a corresponding loss of production. The cost of a tube mill shutdown is approximately 10,000 euros per hour.



Potential savings

€720,000

1 day (= 24 hours) at €10,000 in costs per hour	€240,000
2 days at €10,000 in costs per hour	€480,000
3 days at €10,000 in costs per hour	€720,000
Amount saved per shutdown avoided	€720,000

Finnsementti

Finnsementti produced cement, concrete, lime, and other raw materials at its Pargas and Lappeenranta plants for over a hundred years. Finnsementti produced the majority of Finland's cement supplies in 2012.



Challenges

The Finnish company's biggest concern for a long time was a plant shutdown. This had already been resolved with area-wide and wireless monitoring by OPTIME. However, the vibration specialists wanted to gain deeper insights into the condition of individual machines in particular to enable more detailed analysis of vibration data from motor, fan, pump, and gearbox units. The focus was on an optimal visualization of the data. The customer approached Schaeffler with this request.

Solution

Schaeffler recommended OPTIME ExpertViewer for a more in-depth analysis. The software-based solution provides vibration specialists with a comprehensive set of tools for in-depth and root cause analysis of vibration data. The powerful analysis and the various visualization options on the dashboard enabled the specialists to evaluate the large amount of vibration data even more effectively. It can also be used to evaluate data from other condition monitoring systems, such as SmartCheck or ProLink CMS.

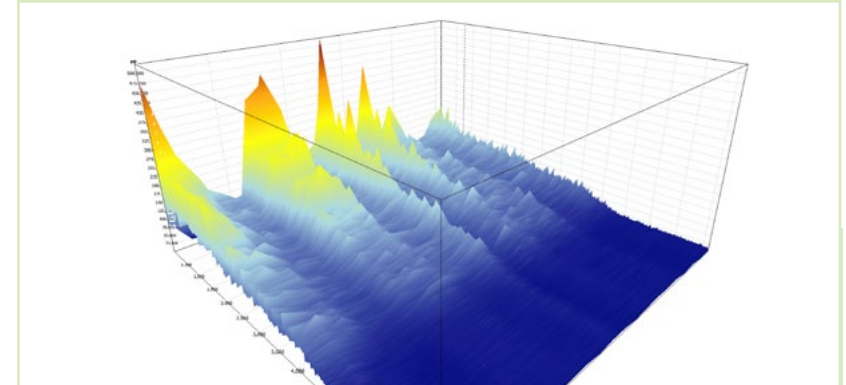

“ExpertViewer is just the right tool for our vibration specialists. It enables them to view the data in detail very easily. A must-have for specialists!”

Toni Virtanen, Maintenance Engineer, Finnsementti Oy

Spenner

Spenner GmbH & Co. KG, headquartered in Erwitte, is a family-owned company and has produced cement, lime, and dry mortar of the highest quality for three generations.



Challenges

The customer operates several cement mills (tube mills) at the Erwitte site and produces at full capacity, although the market situation in the industry is difficult. Despite monitoring with a temperature sensor, a gear unit failure caused a three-week shutdown of a system. The gear unit, which was already badly damaged, had to undergo a cost-intensive complete repair. The customer opted for a Schaeffler solution for the extremely complex diagnoses required of its monitoring.

Solution

Schaeffler employees from the Service division installed an online monitoring system with a total of five sensors on the gear unit and primary reduction gearing. After three months of support provided by Schaeffler specialists in evaluating the data, the customer's employees, who had been trained by Schaeffler, operated the system independently. After only a short period of use, the online measuring system detected gear damage in the gear unit. The gear unit could be replaced during a planned shutdown. Savings: around 27,000 euros.



Potential savings

€27,000

Cost to repair gear damage without online monitoring system	€50,000
Cost for monitoring system project, incl. afterservice	- €18,000
Actual cost to repair if detected early	- €5,000
Savings by avoiding follow-on damage	€27,000

Digital Tools and Support

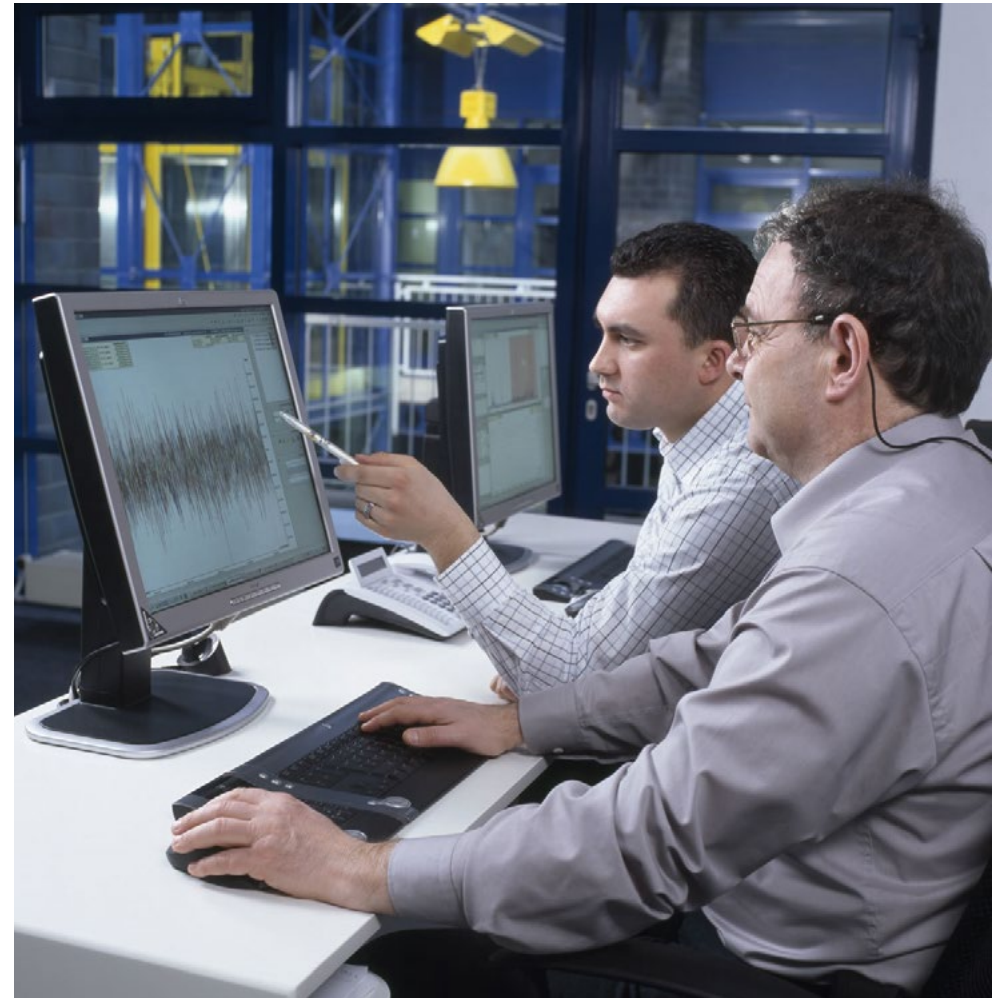

medias

Knowledge database and digital product catalog



In addition to the Schaeffler product catalog, medias provides detailed information on all products and solutions, including a knowledge database with useful materials, such as white papers and online trainings. Calculation and configuration tools provide support in product selection.

More than just an online store

With the medias platform, Schaeffler fully supports its customers in selecting, configuring, and ordering products. It not only gives you detailed information on products and services in the form of a comprehensive knowledge database, but also advanced e-commerce functions and the necessary tools to help you calculate and configure the products you need in line with your requirements. You can get access to additional exclusive content with a free medias Plus membership. Registered business customers can expect an expanded product catalog and even more efficient ordering and communication processes with medias Business.

Switch to Schaeffler quickly and easily

The engineering tool medias-interchange helps to convert rolling bearing names from various manufacturers to the common Schaeffler nomenclature. This also makes it very easy to find out whether Schaeffler carries a corresponding product and whether it is possible to switch. Subsequently, other tools support the selection and configuration of the desired bearing/housing type or linear guide system.



medias offers these engineering tools:

- Linear configurator:
 - Complete system
 - Track
 - Carriage
- Bearing selection assistant
- Housing selection assistant
- Linear selection assistant
- medias-interchange
- Heating manager
- Bearing frequency calculator
- Grease selection guide

Partner Portal

The platform for certified Schaeffler partners

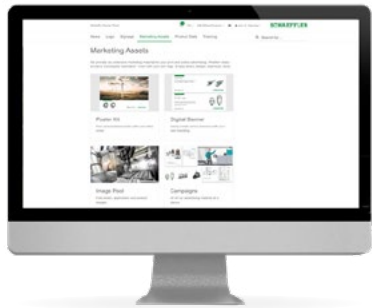

With the Partner Portal, Schaeffler has created a unique platform that provides certified partners with comprehensive information about its broad product and service portfolio and presents innovations. In addition, dealers are provided with useful material to support the sale of and consultations regarding Schaeffler products.

Schaeffler has a long tradition of cooperating closely with manufacturers and customers in the development of products and solutions. This philosophy is also reflected in the Partner Portal. Certified Schaeffler partners can find all the information they need about our products and services here, including product data and images for use in product catalogs, news, and training for their sales staff. In addition, our partners receive access to exclusive marketing material which can help gain customers.

A new form of digital collaboration

The medias affiliate program takes the collaboration between Schaeffler and its partners to a new, digital level. Certified partners can provide references to medias using personalized links that display the partner company prominently on every page. Using the wish list, customers can submit inquiries about the relevant products directly to the relevant Schaeffler partner. At the same time, both the customer and the partner benefit immensely from all the functions offered by medias and the opportunities it creates for technical sales consulting.



What you will find on the Partner Portal:

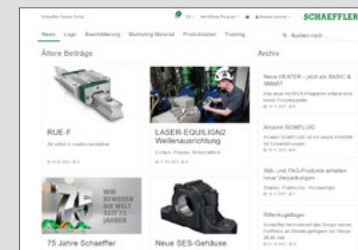

- News and updates
- Training
- Campaign material on products and industries
- Product information
- Marketing materials with individual personalization options

Expert Services

Condition monitoring and maintenance



Schaeffler services provide support for the use of suitable monitoring systems. This includes not only hardware selection, but also system configuration and, where necessary, its integration into existing systems. Condition monitoring during operation is also provided on request.

Our service specialists support customers throughout the entire service life of their equipment and bearings. They advise about suitable monitoring solutions prior to purchase, and subsequently provide on-site or remote installation assistance and support for configuration and commissioning. On request, they can also provide continuous condition monitoring during operation via online connection or carry out regular on-site measurements for vibration analyses. If malfunctions occur on a machine, they trace faults through comprehensive diagnostics, such as torque detection or endoscopy. They rectify faults such as unbalances or incorrect lubrication quickly and accurately.

The optimum bearing solution thanks to professional damage analysis

Thai mining company Sasin Mine Co., Ltd. noticed a marked rise in temperature alongside unusual noises in its vibrating screens. Both were incorrectly attributed to quality shortcomings in the FAG bearings that had been installed not long before. An extensive data analysis by experts from Schaeffler identified the actual cause, and an appropriate bearing solution was implemented using the BEARINX calculation program, which prevented unnecessary long-term system downtime.



Services at a glance

- Condition monitoring consulting
- System history
- On-site support for installation and commissioning
- Remote support during installation
- Vibration analyses
- Remote monitoring
- Maintenance and repair

Trainings

Certified expertise from maintenance specialists



Customized training modules familiarize customers with all important Schaeffler products for bearing maintenance. Customers learn details about proper lubrication and detailed know-how about condition-based machine monitoring.

The training courses offered for condition-based machine monitoring start with basic knowledge and an overview of the products that can be used in condition monitoring. Additional training courses expand the theoretical expertise gained and are complemented by practical exercises. They prepare for certification courses according to ISO 18436-2. Customers can have their knowledge tested and certified at various levels. Training programs tailored to specific needs are available. In these cases, the modular training program is also customized for balancing bearings or on the subject of lubrication.

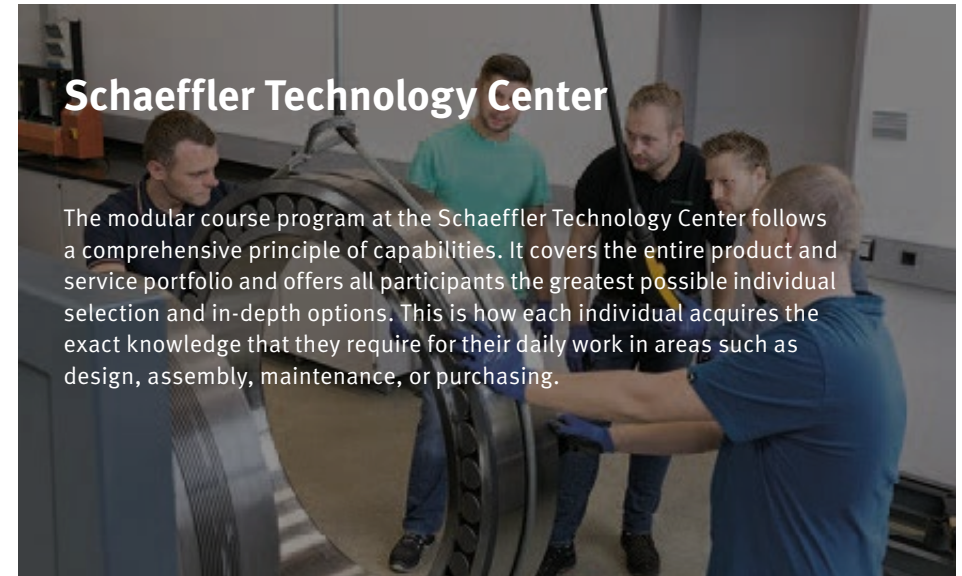

Schaeffler Technology Center

The modular course program at the Schaeffler Technology Center follows a comprehensive principle of capabilities. It covers the entire product and service portfolio and offers all participants the greatest possible individual selection and in-depth options. This is how each individual acquires the exact knowledge that they require for their daily work in areas such as design, assembly, maintenance, or purchasing.



Products

- Product training sessions from the rotary, linear, and service areas
- Sector-based product training sessions



Assembly

- Assembly and disassembly of rotary and linear products
- Large bearing assembly



Basic principles

- Basic training sessions, including sector relevance
- Kinematics, speed, lubrication, and fault analysis



Lifetime Solutions

- Vibration analysis
- Balancing and aligning
- Condition monitoring

Aftersales and Customer Service



Literature and Publications



- Condition monitoring with OPTIME
- Brochure
- Cement publications
- Catalog HR1:
- Condition Monitoring Manual (print edition)

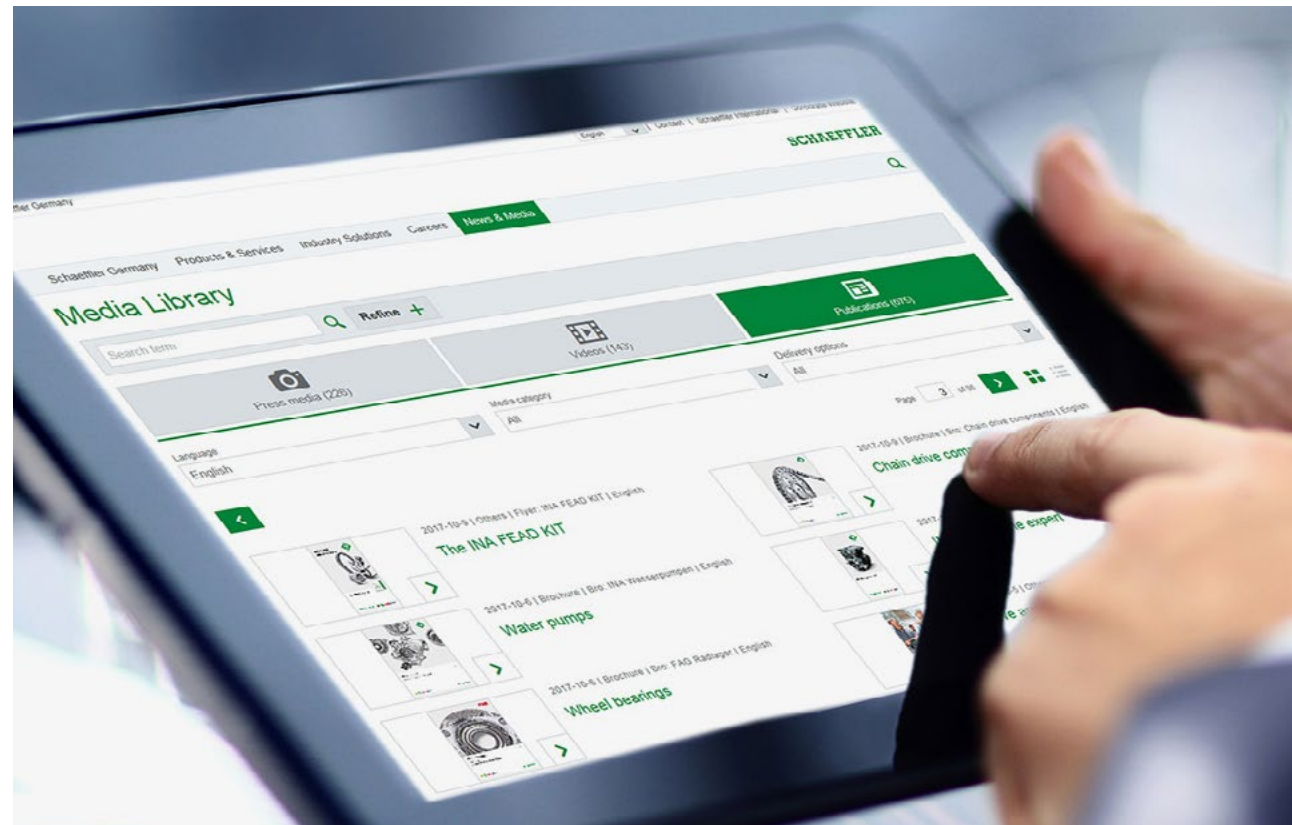

Contact

How can we assist you?
Do you have questions about our products or solutions?
Feel free to contact us at any time!

We are there for you at all times and in any location.
You can find a Schaeffler worldwide contact here.



We pioneer motion